



# Vaibhav Engineering

Conveyor System | Handling Trolley | SPM

One Stop Solution for Material handling System | SPM – Automation Machines

Address :- 485-486/56 Astamangal Industrial Estate,  
Opp. Orlikon, Makarpura GIDC, Vadodara-390010

E-mail :- vaibhav.engg07@gmail.com

Mobile No :- + 91 9724218511 | 9099687877

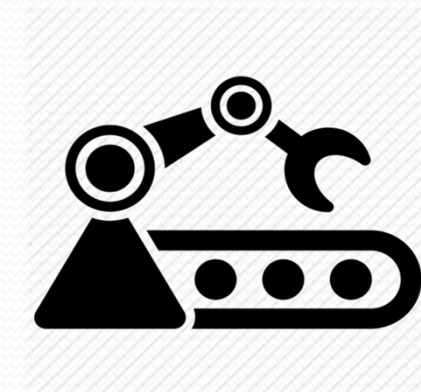
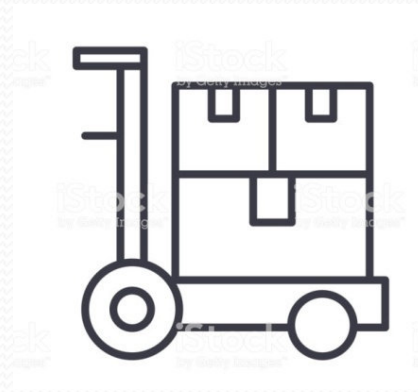

[www.vaibhavengineering.org](http://www.vaibhavengineering.org)

## Company Business Segments

### We representing manufacturing with Quality & Timely delivery to meet Customer Satisfaction

The Core focus of the company lies in superior quality and excellent customer service with expertise in the industry and constant innovation in the industry.

'We are manufacture of Conveyor systems, Material Handling Trolleys & Systems, Customize SPM – Automation Machine, Assembly line & Assembly tables , Aluminum section work station & working tables, Heavy duty Fabricated rack, FIFO rack & Pipe joint racks, Customize fabrication in MS & SS etc...

Company also undertakes turnkey project with design, manufacturing, supply with commissioning activities.

## Conveyor System



### ■ Suspension Rod/Shaft Loading & Unloading Conveyor

Complete Production Line Conveyor Set-up for Suspension Rod/Shaft Loading & Unloading (Grinding Process) with OK-NOT OK (Rejection System) part Shorting or segregation.

## Conveyor System



- **PVC Belt Conveyor For Material Collection**

Belt Conveyor for Machine Out-put Collection.  
Aluminum Section Frame with PVC Green Belt

## Conveyor System

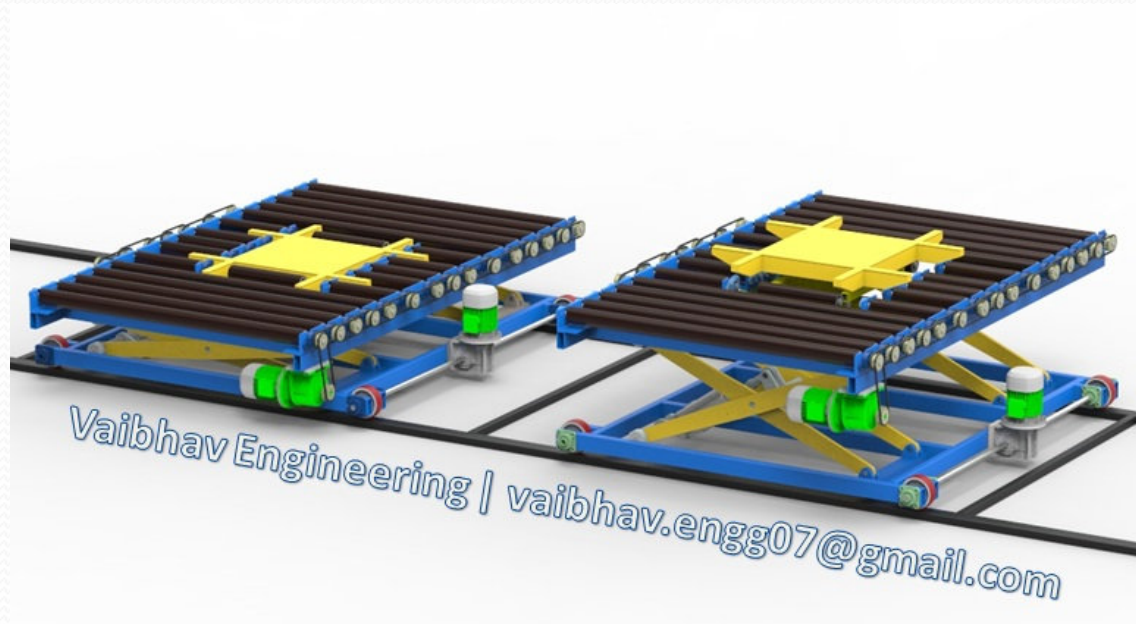

### ▪ Shuttle / Transportation Conveyor

- > Shuttle Roller Conveyor system for Continue Production Line with Component/Part Rotating provision.
- > Loading & Unloading on different Height with Pneumatic Scissor Up-Down Provision.
- > Provision of traveling to unload the part on different station.

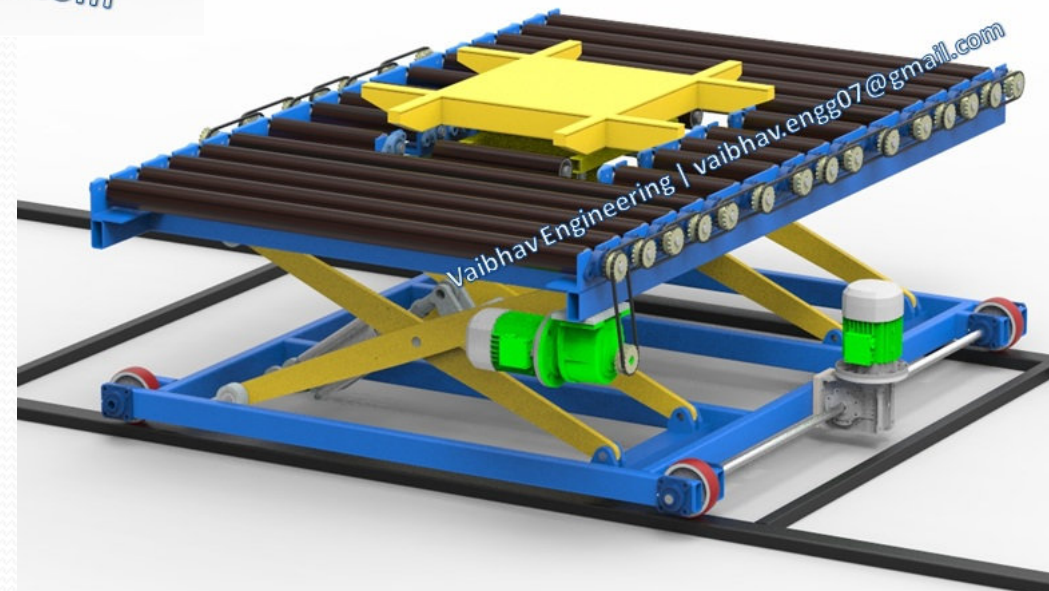

## Material Handling Trolleys



## Material Handling Trolleys



## Material Handling Trolleys





# Material Handling Trolleys

Vaibhav Engineering

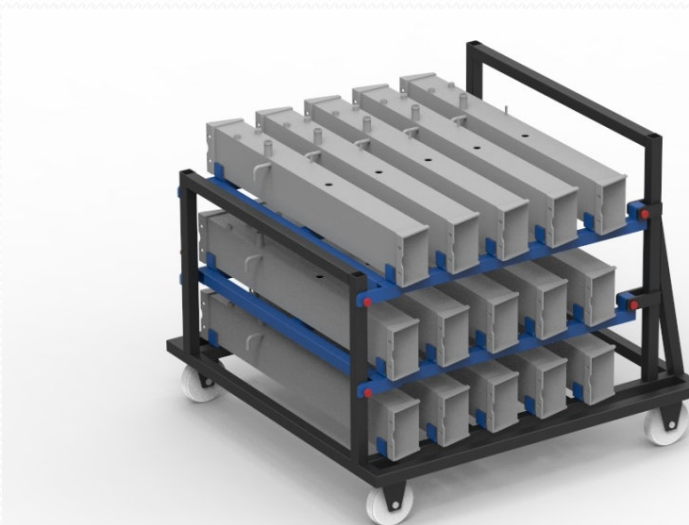
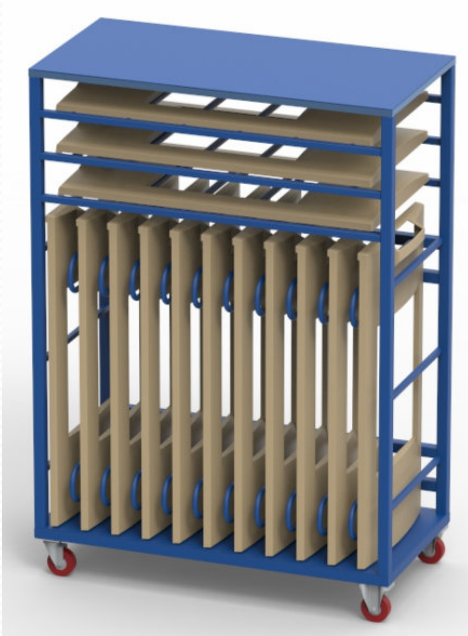

Material Handling Trolleys

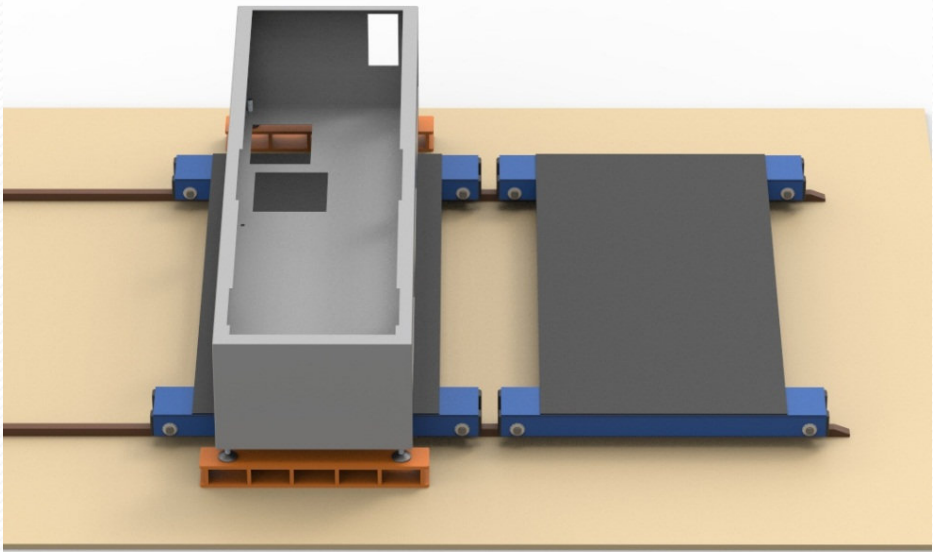
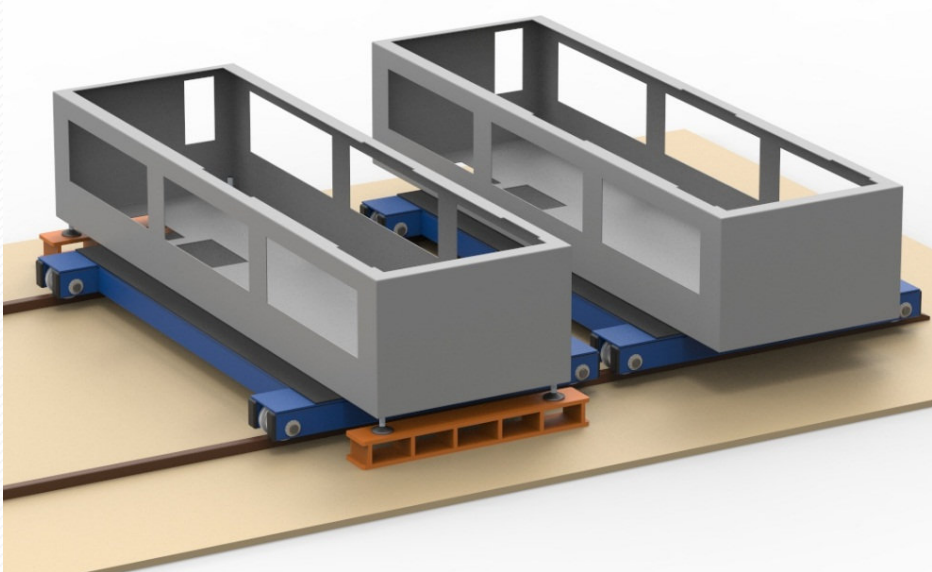
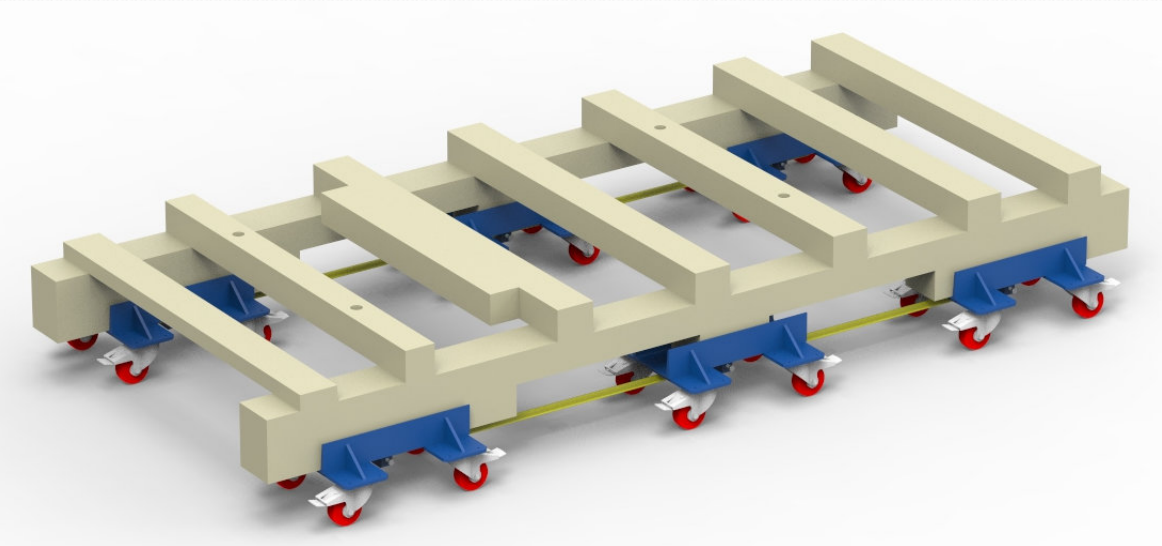
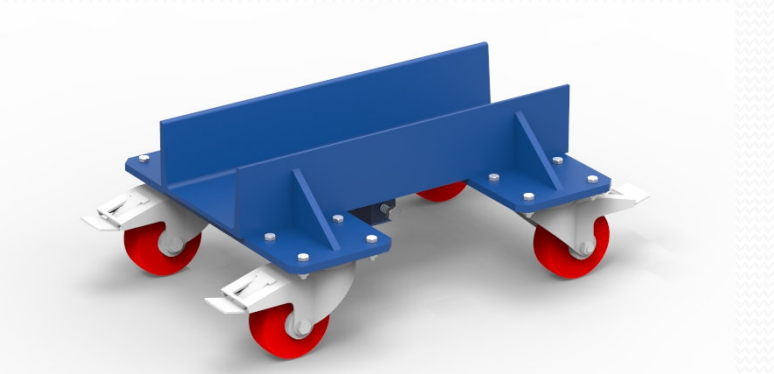

## Assembly & QA Tables / Work Station

Vaibhav Engineering



## SPM Machines

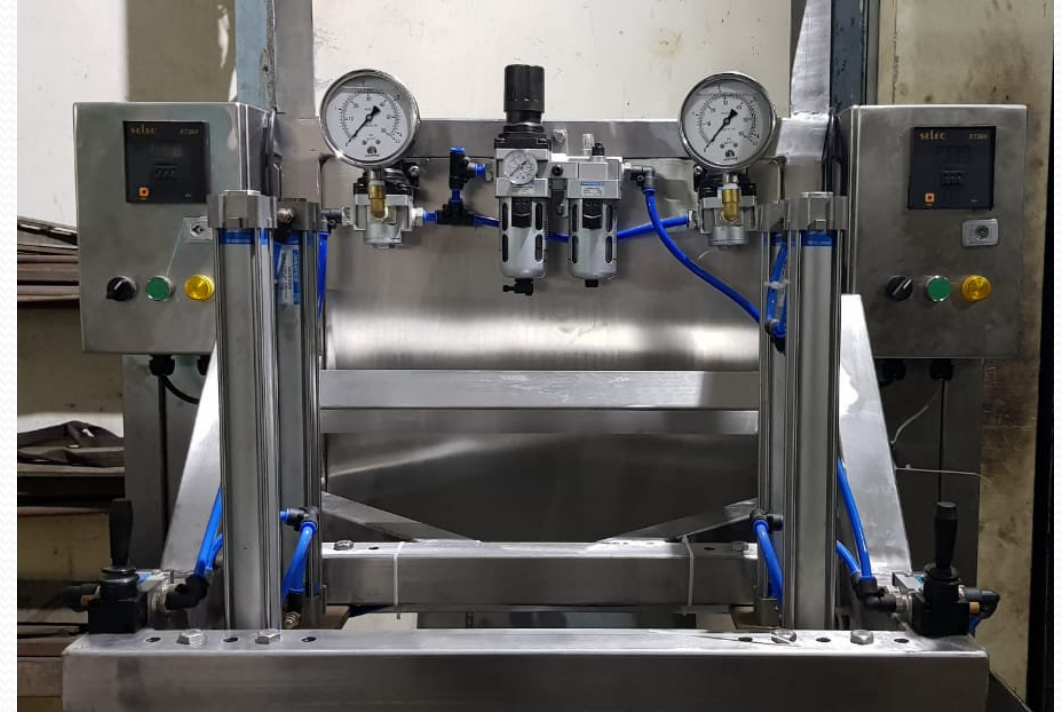

### ■ Water Deep Testing System

Water Deep Testing Tank with Timer base system. Part Up-Down Provision – Testing Cycle with control air are operated with Single Push Button.

## SPM Machines



- Hydraulic Scissor Lifter Table



## Jig & Fixtures

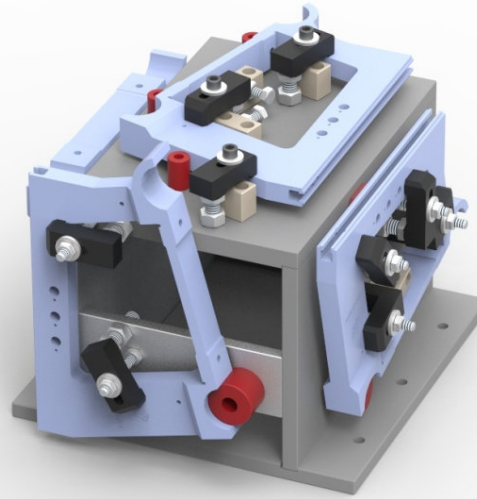

- **Machining Fixture for VMC**  
Total 4 Nos of operations in difference position are accommodate in fixture.  
Out-Put :- 1 piece/Cycle

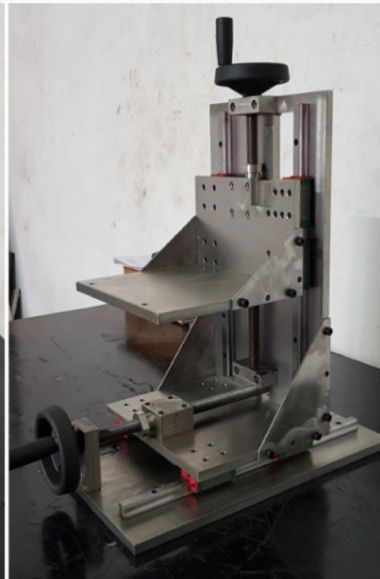

- **Sensor Adjustment Unit**  
Sensor Adjustment in X (Up-Down) & Z (Front-Back) Direction

## Jig & Fixtures



- **Hole CD Checking Gauge (1800 mm L)**  
CD Checking gauge in both X (Reference to Base) & Y (Reference to Hole) Direction

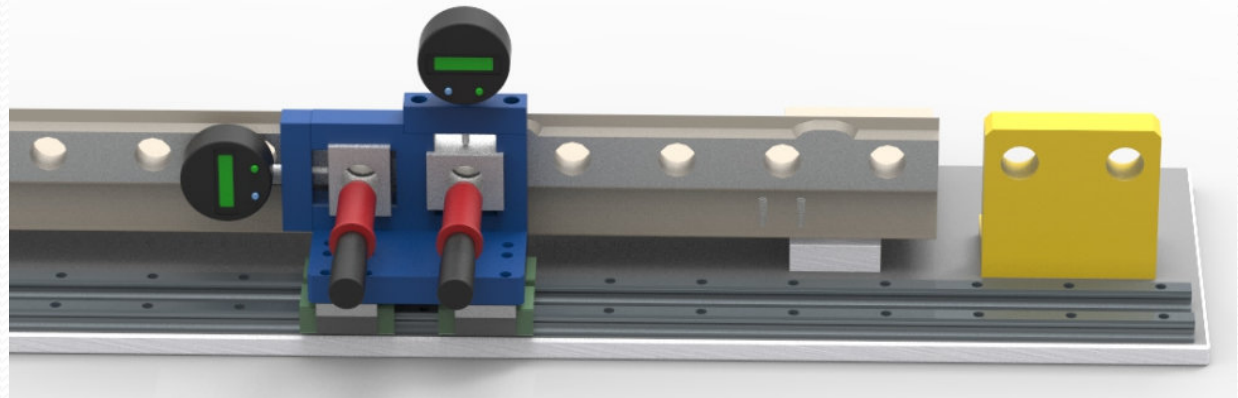

# Jig & Fixtures

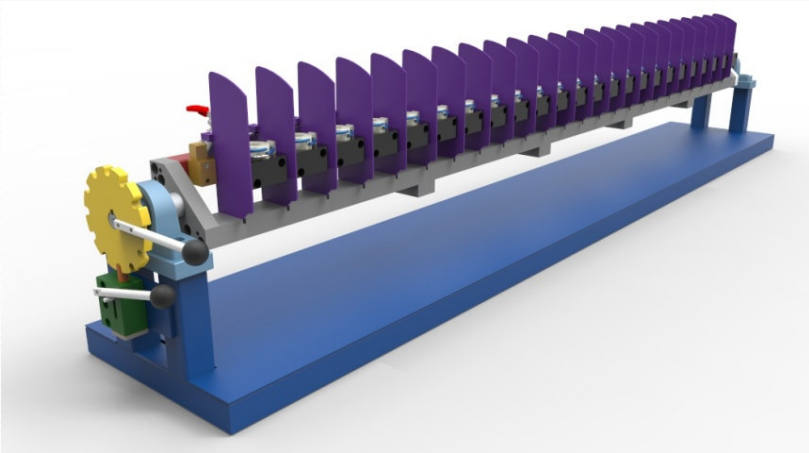

▪ Rotary Indexing Type Assly Fixture





# Jig & Fixtures

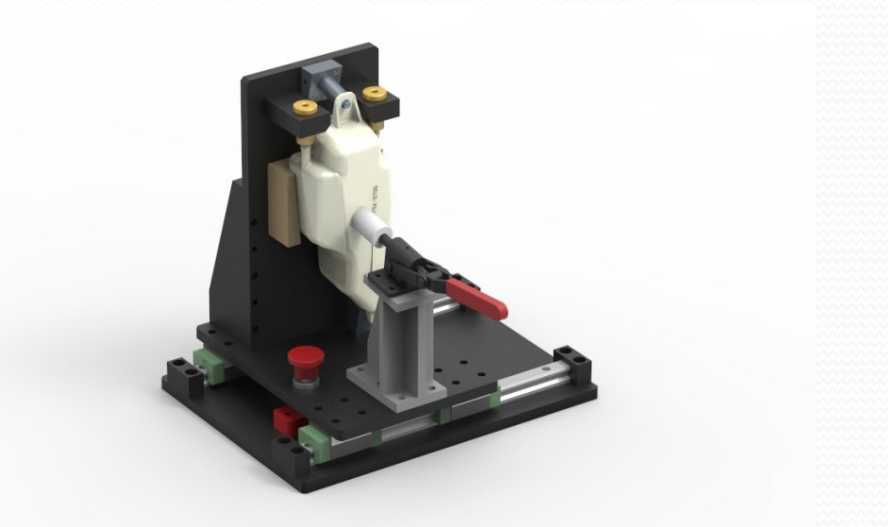
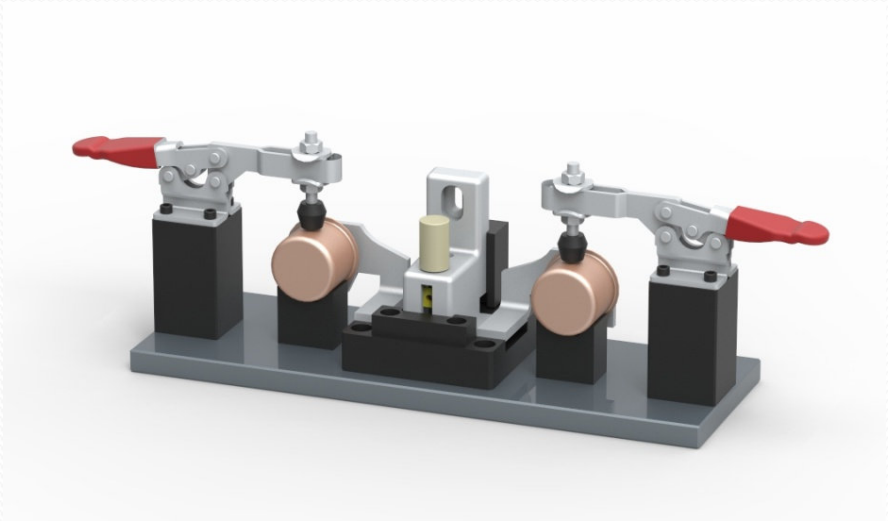
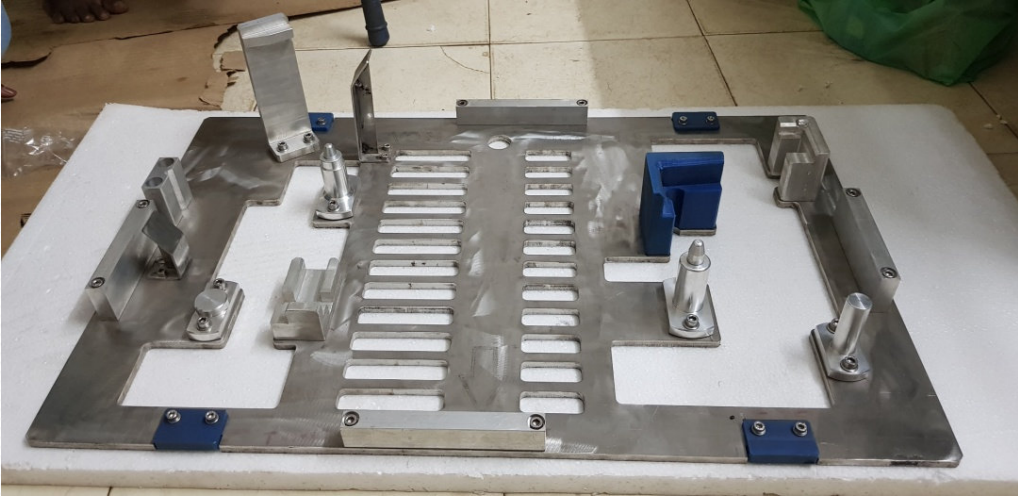

## Jig & Fixtures

- Rotary Indexing Type Pipe Drilling Fixture

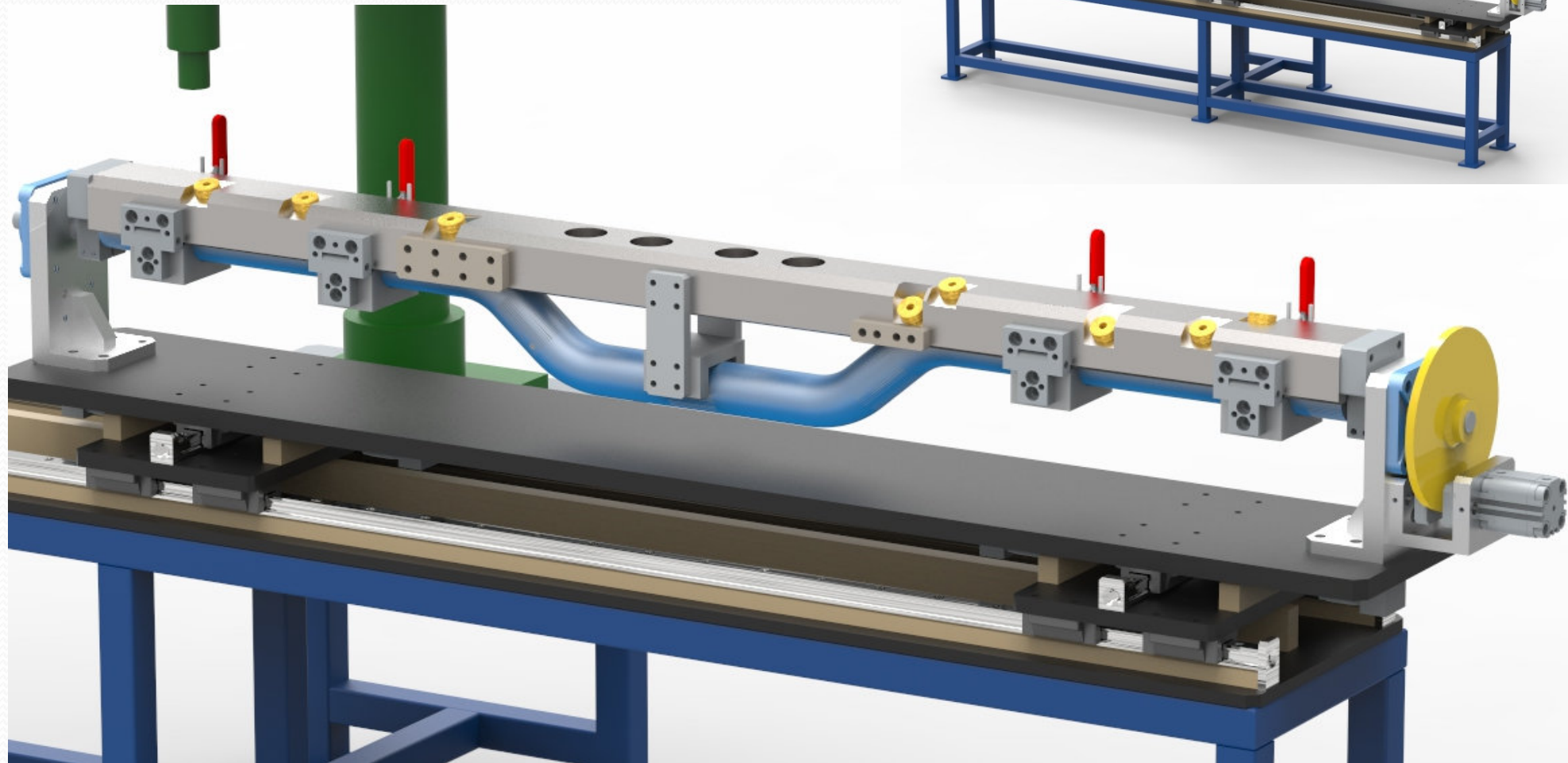

Jig & Fixtures

- Rotary Indexing Type Welding Fixture

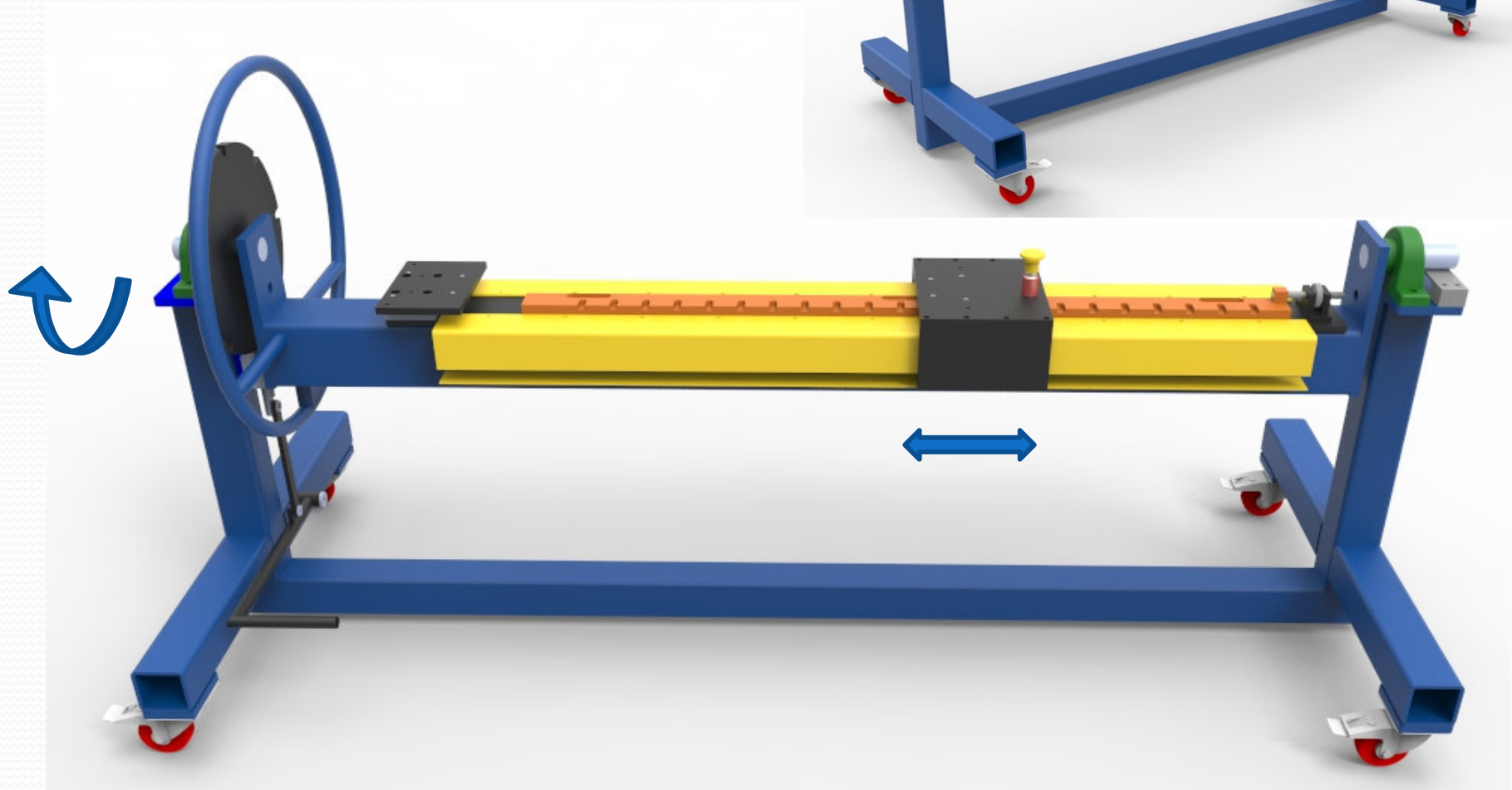

# Jig & Fixtures

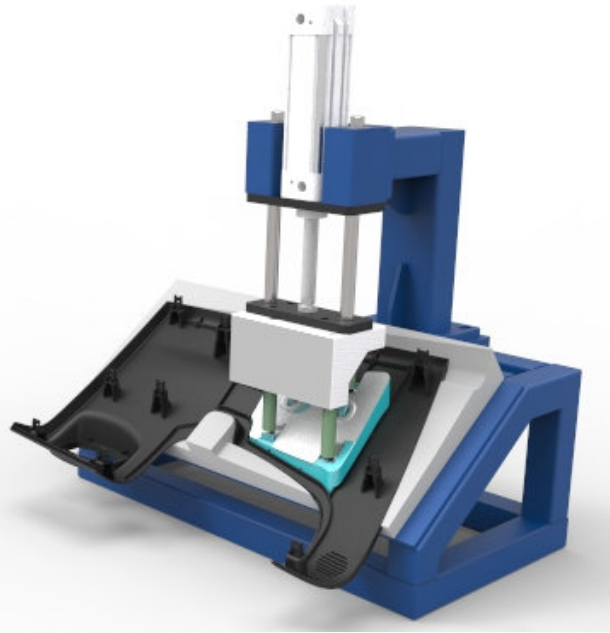
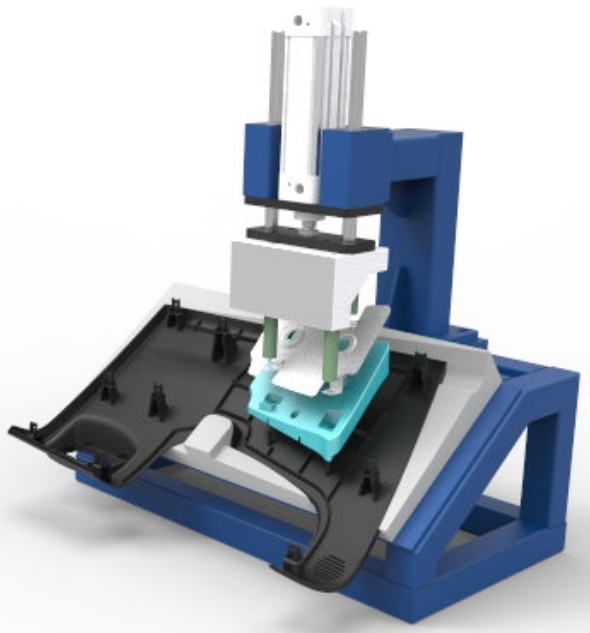
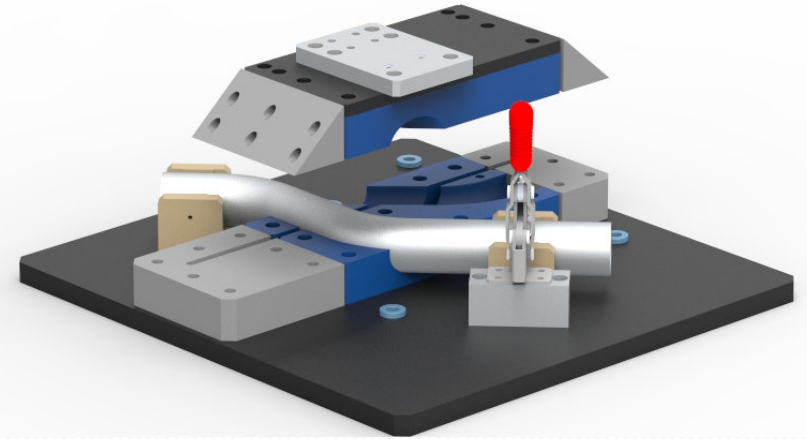
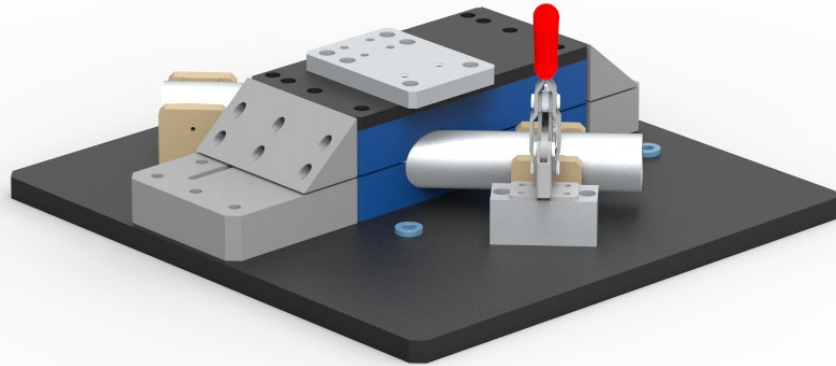

## Valuable Costumers

