



Textile



Power Plant



Paper



Ceramic



Pharma



Water Treatment



Plastic



Chemical



Foundries



Refinery



Cement



Food



Office & Factory:

Venus Compressors Pvt. Ltd.

60/3, Diamond Industrial Estate, N.H.8, Nr. Unnati Industrial Corporation,

Nana Chiloda, Naroda, Ahmedabad -382330

Tele/Fax: +91-2282 1999, 2970 0066 • Mo.: +91 99259 68840

E-mail: inquiry@venuscompressor.com, sales@venuscompressor.com

Web: www.venuscompressor.com

An ISO 9001:2008 Company



Intertek



**Compressor Technology
Beyond Innovation**



www.venuscompressor.com

Company Profile

Venus group of company is engaged in the field of Air compressors since two decades. It had achieved a trusted name in Screw compressors. Permanent Magnet technology & Oil Free water Injected Screw Compressors are the biggest achievement of company. Venus offers the complete solution for compressed air systems, Screw air compressors with TSC Services, Permanent magnet screw air compressors, Refrigerant air Dryers, Oil Free Water Injected Screw Compressors, Air Receivers, Oil Free Piston Compressors, High Pressure Reciprocating Air Compressors, Low Pressure Reciprocating Air Compressors, Micro Filters.

Innovation, High Standard Engineering Products, Prompt After Sales Services, Best Quality are pillars of the company. Venus is offering the systems with latest technology, Innovative Design, High Efficiency Compressor with Power saving modes.

Everyone at **VENUS** from the engineers to the sales staff, has the experience, skill and dedication team to provide customers, finest quality and service anywhere. Our engineers and technicians ensure that each machine is designed to package products in the most efficient and effective way possible. Our highly skilled mechanics take pride in precisely assembling quality parts into exceptional machines. Our trained technicians check each assembled machine to see that it is operating perfectly before it leaves the plant. Finally, the sales staff utilizes its extensive knowledge to ensure that customers receive the product they had ordered.

Mile Stone

We Launched the Permanent Magnet motor technology in screw compressors which led to roll out new technology throughout the nation in industries. This has brought 30% power saving in compressed air systems.

Oil free compressed air requirement got a simplest, efficient, economic technology of water injected screw compressors. Which is successfully serving Pharma, Food, refinery & many more.

Vision & Mission

Company is continuously working on compressed air technology beyond innovation by giving "More Power Saving", "Intelligence Compressor Controller", "Smart Synchronising System", "Zero Break Downs", "Local and remote operated System", "One Touch/Call Service System".

Company Mission is to reach at the highest sales of compressors in PAN India in this decade.

Our Products

- Reciprocating Air Compressors
- 100% Oil Free Compressors
- Air Dryers
- Vacuum Pumps
- High Pressure Air Compressors

Piping Parameter & Selection

Flow Rate			Length									
			164ft	328ft	492ft	984ft	1640ft	2460ft	3280ft	4265ft	5249ft	6561ft
Nm ³ /h	NI/min	cfm	50m	100m	150m	300m	500m	750m	1000m	1300m	1600m	2000m
10	167	6	16.5	16.5	16.5	16.5	16.5	16.5	16.5	25	25	25
30	500	18	16.5	16.5	16.5	25	25	25	25	25	25	40
50	833	29	16.5	25	25	25	25	25	40	40	40	40
70	1167	41	25	25	25	25	40	40	40	40	40	40
100	1667	59	25	25	25	40	40	40	40	40	40	63
150	2500	88	25	40	40	40	40	40	40	63	40	63
250	4167	147	40	40	40	40	63	63	63	63	63	63
350	5833	206	40	40	40	63	63	63	63	63	63	76
500	8333	294	40	40	63	63	63	63	63	76	63	76
750	12500	441	40	63	63	63	63	76	76	76	76	100
1000	16667	589	63	63	63	63	63	76	76	100	76	100
1250	20833	736	63	63	63	63	63	100	100	100	100	100
1500	25000	883	63	63	63	76	76	100	100	100	100	100
1750	29167	1030	63	63	76	76	76	100	100	100	100	100

Air Flow Unit Conversion

Air Flow	Symbol	Convert to	Conversion factor
Cubic feet per minute	scfm	m ³ h ⁻¹	x 1.699
Cubic feet per minute	scfm	m ³ m ⁻¹	x 0.0283
Cubic feet per minute	scfm	l min ⁻¹	x 28.316
Cubic feet per minute	scfm	l s ⁻¹	x 0.4719
Cubic metres per minute	m ³ min ⁻¹	scfm	x 35.315
Cubic metres per hour	m ³ h ⁻¹	scfm	x 0.5885
Litres per minute	l min ⁻¹	scfm	x 0.0353
Litres per second	l s ⁻¹	scfm	x 2.119

Pressure Unit Conversion

Pressure	kPa	bar	psi	kg cm ⁻²
1 kPa	1	0.01	0.145	0.0102
1 bar	100	1	14.5	1.02
1 psi	6.9	0.069	1	0.07
1 kg cm ⁻²	98	0.981	14.2	1

Screw Compressor

Technical Specification

Model		TSC-10A	TSC-15D	TSC-20D	TSC-25D	TSC-30D	TSC-40D
Power	(KW)	7.50	11	15	18.50	22	30
RPM	min	3200	2900	2900	2900	2900	2900
Free Air Delivery	CFM	45.92	65.34	85.07	113.02	134.21	183.66
		38.85	57.22	79.43	109.49	127.15	178.72
		33.55	49.44	70.64	95.36	113.02	137.75
		30.38	46.27	60.04	77.70	98.90	123.62
	(m³/min)	1.30/0.70	1.85/0.70	2.40/0.70	3.20/0.70	3.80/0.70	5.20/0.70
/Mpa	1.10/0.80	1.62/0.80	2.24/0.80	3.10/0.80	3.60/0.80	5.06/0.80	
		0.95/1.00	1.40/1.00	2.00/1.00	2.70/1.00	3.20/1.00	3.90/1.00
		0.86/1.30	1.31/1.30	1.70/1.30	2.20/1.30	2.80/1.30	3.50/1.30
Noise	(db)	62±2	62±2	62±2	62±2	68±2	72±2
Machine Dimension	(L*W*H)mm/ Weight(KG)	960*680 *960/280	980*710 *1030/330	980*710 *1030/380	1310*780 *1220/500	1310*790 *1250/530	1480*890 *1470/745
Air outlet	Inch/mm	G1/2"	G3/4"	G3/4"	G1"	G1"	G1 1/2"

* A: Belt Driven • D: Direct Driven • * Cooing Type: Air Cooling

Features

- Direct Driven feature provide zero transmission losses with low RPM Screw Element
- 2 Years warranty for Screw Air End
- Oil cooler is designed for 45° C ambient Temp, which is suitable for Indian industries circumstances
- All parts are designed with universal design code / standard
- Consumable cost is Rs. 3.50 upto Tscs 50 D (Price of Consumable Lowest)
- 100% imported from LOFFTOL COMPRESSORS USA. Visit LOFFTOL.COM for more information
- No Hose pipe or any Rubber parts in System

10 Year Life Cycle Cost

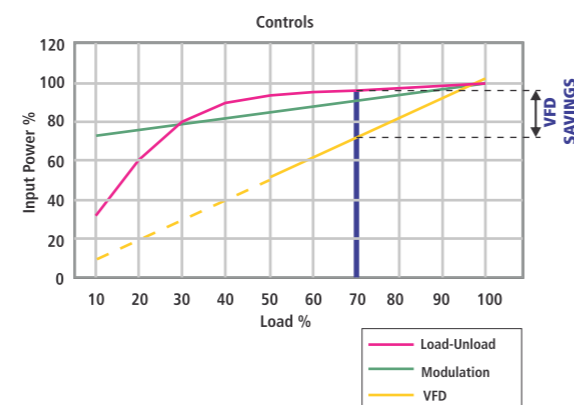
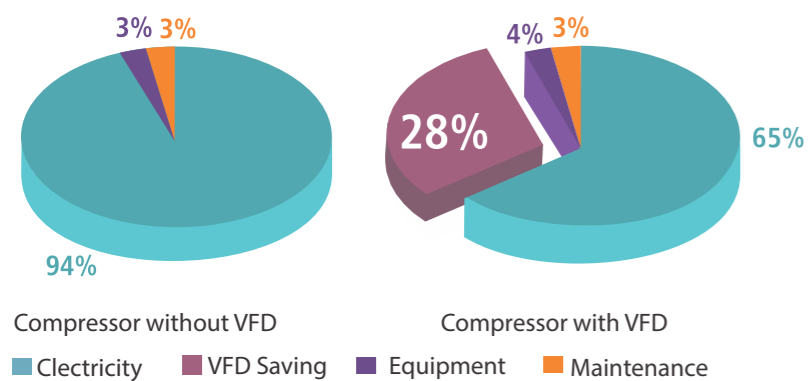

TSC-50D	TSC-60D	TSC-75D	TSC-100D	TSC-120D	TSC-150D	TSC-175D	TSC-200D
37	45	55	75	90	110	132	160
2900	2900	2900	2900	2900	2900	2900	2900
240.17	282.56	370.86	480.35	575.71	716.99	883.00	956.63
228.17	271.96	353.26	469.75	540.10	681.67	812.36	935.98
190.73	247.24	307.28	409.71	515.67	600.44	706.40	801.31
137.75	215.45	264.90	346.13	434.43	515.67	635.76	709.93
6.80/0.70	8.00/0.70	10.50/0.70	13.60/0.70	16.30/0.70	20.30/0.70	25.00/0.70	27.08/0.70
6.46/0.80	7.70/0.80	10.00/0.80	13.30/0.80	15.30/0.80	19.30/0.80	23.00/0.80	26.50/0.80
5.40/1.00	7.00/1.00	8.70/1.00	11.60/1.00	14.60/1.00	17.00/1.00	20.00/1.00	22.70/1.00
3.90/1.30	6.10/1.30	7.50/1.30	9.80/1.30	12.30/1.30	14.60/1.30	18.00/1.30	20.10/1.30
72±2	72±2	75±2	75±2	75±2	78±2	78±2	78±2
1490*890	1500*950	1625*980	1850*1080	2200*1380	2210*1310	2210*1310	2700*1460
*1490/780	*1475/870	*1625/1040	*1635/1360	*1750/2150	*1750/2360	*1900/3150	*2010/3480
G1 1/2"	G1 1/2"	G1 1/2"	G2"	G2"	G2 1/2"	G2 1/2"	G3"

The company on product improvement and reserves the right of design improvement parameters are subject to change without prior notice.

Model	Capacity (cfm)	Working Pressure
TSC-30V	127.15	8.00
TSC-40V	178.72	8.00
TSC-50V	228.17	8.00
TSC-60V	271.96	8.00
TSC-75V	353.26	8.00
TSC-100V	469.75	8.00
TSC-120V	529.80	8.00
TSC-150V	681.67	8.00
TSC-175V	812.36	8.00
TSC-200V	935.98	8.00

Example: For a demand of 70% of full load, the savings from VFD compared to a fixed speed compressor will be about 28% of full load power

Advantages

Mechanical

- Minimum maintenance
- Smooth Start
- Smooth control

Electrical

- Low starting current
- High efficiency
- Improved power factor
- Reduced maximum Demand



Permanent Magnet Screw Compressor



The introduction of the advantage of VENUS series permanent magnet compressors

Energy saving efficiency:

Under full load condition, permanent magnet compressors can supply the maximum air output under the minimum energy consumption, and when the load rate is lower by 20%, can still guarantee the efficiency.

permanent magnet compressors always stays as much as 95% of running efficiency within the scope of the whole gas regulating speed.

Save bandwidth control pressure waste of electricity (Variable frequency energy saving): In order to avoid the frequent starts that result in the cause to the unit, the impact on the grid, stationary compressor must set up a minimum of 1bar pressure range (The minimum and maximum pressure of the air compressor), the control of machine needs to have a pressure gradient when some units are used together, the pressure of the system will be wider. VENUS series are of variable frequency control, can start and stop with unlimited times, so no need to set the pressure range, it only needs to set a pressure point, every saving of 0.14 bar pressure range, it will save the energy consumption by 5-7% for the whole system.

VENUS series double screw host with its continuous optimization of rotor type line and internal structure, provides industry leading level specific power. The host energy efficiency is above the first level of energy efficiency of the national standard.

The incomparable reliability:

The connecting parts of permanent magnet compressors are much less than that of other equivalent compressors, is directly driven by permanent magnet compressors, when air compressor is running, it doesn't need to consider the gear, pulley, belt, even the shaft or shaft seal wearing of moving parts.

The remarkable technology:

The permanent magnet structure of permanent magnet compressors revolutionary unique uses less electricity to provide more compressed air and bigger air volume adjustment range. Comparing with ordinary air compressor, it can save energy by 15%- 38%, comparing with common variable frequency compressor, it can save energy by 5%- 10%.The bigger of the system gas fluctuation, the more obvious of the energy saving effect appears.

Working condition of energy saving:

Permanent magnet compressor can keep high efficiency even in low speed, ensuring its obvious advantage in energy saving when the gas is little. The variable frequency ranges from 5% to 100%, and the ordinary variable frequency can only be from 50% to 100%.

The common variable frequency air compressor saves energy only when unloading the system (Variable frequency energy saving):

There will be an unloading time for the stationary air compressor during its air consumption fluctuates, even when running idly it will still need to consume 45% of its electricity, but VENUS series of variable frequency control can have no unloading, there is no waste existing. If the more sets of the systems used, the more of energy saving it will be.

Saving energy when it starts up (Variable frequency energysaving):

Stationary air compressor startup current is about 3 to 6 times of the rated working current, if frequently started, it will waste a lot of energy, VENUS series start with no current shock, and startup as soft start, the maximum current shall not exceed its rated working current, there will be no waste of energy. At the same time, it also greatly reduces the impact on power grid equipment, and won't cause harm to electrical equipment.

One shaft structure:

Permanent magnet motor adopts the embedded integrated with compressor shaft directly connected structure, the structure is more compact, no need to use belt, gear coupling and so on of transmission components, completely without transmission loss, and the transmission efficiency is of approximate 100%.

Screw host:

VENUS series double screw host is the combination of science and ideal, accurate and exquisite combination, make the perfect efficient core host, the host on the research and development, developed jointly by college and enterprise, dominated by scientific leading scientists doctoral tutor, national professional laboratory testing, key parts are finite element strength analysis. In order to ensure the quality of each part can be maximum



optimization, provide strong technical support for the product stability, high efficiency and long running. Comprehensive optimization of the tooth surface precision of the rotor and rotor meshing sex, optimize the end surface precision of the screw and the rotor position precision, optimization of the exhaust pressure, displacement and the best combination of vent, with advanced manufacturing equipment and superb manufacturing process, create high efficiency, high reliability, high precision screw host. VENUS series double screw compressor with its continuous optimization of rotor type line and internal structure, provides industry leading level specific power. The host energy efficiency is above the first level of energy efficiency of national standard.

High efficiency permanent magnet motor:

Equipped with high efficiency permanent magnet compressor (PM compressor), compared with ordinary high-frequency compressor, energy-saving performance is more outstanding. Especially in low speed, it can still keep high efficiency of compressor. At rated speed or different speed conditions, the efficiency of permanent magnet compressor is higher than that of the ordinary variable frequency motor, energy saving effect is more remarkable.

Adopt the one-piece structure, the size of the product is small, generally about a third of the ordinary high-frequency motor size, space is saved, and easy to installation and disassemble.

Drive characteristics of VENUS series double screw host with efficient permanent magnet compressor:

Permanent magnet compressor adopts high performance bonded ndfeb permanent magnets, without losing magnetism even at 120 degrees, the service life is more than 15 years.

Stator coil adopts inverter dedicated corona resistant enabled wire. Insulation performance is outstanding, and the service life is much longer.

It can achieve soft start, the motor current won't exceed full load current at the running time. It greatly reduces the impact to power grid equipment at the same time, and it will not cause damage to electrical equipment.

No motor bearing: rotor with permanent magnet is installed directly on the outer part of the male rotor shaft, such structure doesn't need to use bearing, therefore it can eliminate the fault point from the motor bearing.

Permanent Magnet Screw Compressor



Benefits of Permanent Magnetic Motor

The benefits of PERMANENTMAGNET field-excited motors over electromagnetically-excited motors include:

- Higher efficiency since no electrical energy is used or losses incurred for developing or maintaining the motor's magnetic field.
- Higher torque and power density.
- Linear torque speed characteristics that are more predictable.
- Better dynamic performance due to higher magnetic flux density in air gap.
- Simplified construction and essentially maintenance-free.
- More compact size.
- Less bearing current due to large air gap.
- Low temperature due to less rotor losses.
- Ramp up time- shorter, constant power up to maximum speed.



Be a part of **Global Energy Saving**, by using **VENUS** make **Permanent Magnet Motor Screw Compressors**

Technical Specification

Model	Power	RPM	Free Air Delivery	Working Pressure	Noise	Machine Dimension	Air Outlet
	KW	Max.	CFM	Mpa	db	(L*W*H)mm/(Weight) KG	Inch
TSC- 15 PMV	11	3000	65.34	0.80	62±2	980*710*1030/330	G3/4"
			49.44	1.00			
			46.27	1.30			
TSC -20 PMV	15	3000	85.07	0.80	62±2	980*710*1030/380	G3/4"
			70.64	1.00			
			60.04	1.30			
TSC -25 PMV	18.5	3000	113.02	0.80	62±2	1310*780*1220/500	G1"
			95.36	1.00			
			77.70	1.30			
TSC -30 PMV	22	3000	134.21	0.80	68±2	1490*950*1210/530	G1"
			113.02	1.00			
			98.90	1.30			
TSC -40 PMV	30	3000	183.66	0.80	72±2	1620*1120*1400/745	G1 1/2"
			137.75	1.00			
			123.62	1.30			
TSC -50 PMV	37	3000	240.17	0.80	72±2	1620*1120*1400/780	G1 1/2"
			190.73	1.00			
			137.75	1.30			
TSC -60 PMV	45	3000	282.56	0.80	72±2	1620*1120*1400/870	G1 1/2"
			247.24	1.00			
			215.45	1.30			
TSC -75 PMV	55	3000	370.86	0.80	75±2	2020*1370*1660/1040	G 2"
			307.28	1.00			
			264.90	1.30			
TSC -100 PMV	75	3000	480.35	0.80	75±2	1850*1080*1635/1360	G2"
			409.71	1.00			
			346.13	1.30			
TSC -120 PMV	90	3000	575.71	0.80	75±2	2200*1380*1750/2150	G2 1/2"
			515.67	1.00			
			434.43	1.30			
TSC -150 PMV	110	3000	716.99	0.80	78±2	2210*1310*1900/2360	G2 1/2"
			600.44	1.00			
			515.67	1.30			
TSC -175 PMV	132	3000	883.00	0.80	78±2	2210*1310*1900/3150	G2 1/2"
			706.40	1.00			
			635.76	1.30			
TSC -200 PMV	160	3000	956.63	0.80	78±2	2700*1460*2010/3480	G3"
			801.31	1.00			
			709.93	1.30			

The company on product improvement and reserves the right of design improvement parameters are subject to change without prior notice.

Touch graphic PLC Controller

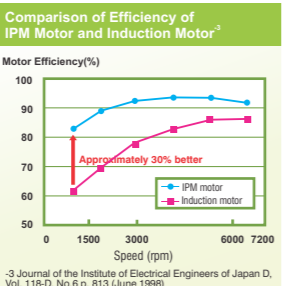

Direct Drive



Shaft Less Motor



Oil Free Water Injected



Technical Specification (Screw Air Compressor)

		OF-10W	OF-15W	OF-20W	OF-25W	OF-30W	OF-40W	OF-50W	OF-60W	OF-75W	OF-100W
Item	Unit	Specification	Specification	Specification	Specification	Specification	Specification	Specification	Specification	Specification	Specification
Rated exhaust pressure	MPa	0.7/0.8/1.0	0.7/0.8/1.0	0.7/0.8/1.0	0.7/0.8/1.0	0.7/0.8/1.0	0.7/0.8/1.0	0.7/0.8/1.0	0.7/0.8/1.0	0.7/0.8/1.0	0.7/0.8/1.0
Rated exhaust capacity	m3/min	1.2/1.1/1.0	1.6/1.5/1.3	2.4/2.3/2.0	3.1/2.8/2.5	3.7/3.4/3.0	5.2/4.7/4.3	6.1/5.6/5.0	7.5/6.8/6.0	10.0/9.0/7.8	13.0/12.0/10.0
Water lubrication	L	20	20	27	27	27	40	40	40	100	100
Intake temperature	C°	2-40C° Under atmospheric pressure	2-40C° Under atmospheric pressure	2-40C° Under atmospheric pressure	2-40C° Under atmospheric pressure	2-40C° Under atmospheric pressure	2-40C° Under atmospheric pressure	2-40C° Under atmospheric pressure	2-40C° Under atmospheric pressure	150 Under atmospheric pressure	200 Under atmospheric pressure
Exhaust temperature	C°	ambient temperature +20C°	ambient temperature +20C°	ambient temperature +20C°	ambient temperature +20C°	ambient temperature +20C°	ambient temperature +20C°	ambient temperature +20C°	ambient temperature +20C°	ambient temperature +20C°	ambient temperature +20C°
Drive mode		Direct driven	Direct driven	Direct driven	Direct driven	Direct driven	Direct driven	Direct driven	Direct driven	Direct driven	Direct driven
RPM	rpm	2940	2940	2940	2940	2940	2940	2940	2960	2960	2960
Rated power	kw	7.5	11	15	18.5	22	30	37	45	55	75
Exhaust oil content	ppm	0	0	0	0	0	0	0	0	0	0
Cooling method		Water cooling	Water cooling	Water cooling	Water cooling	Water cooling	Water cooling	Water cooling	Water cooling	Water cooling	Water cooling
Noise Level	dB(A)	61	61	61	61	61	64	66	66	66	70
Outline size	LxWxH (mm)	1100x800 x1000	1100x800 x1000	1400x1000 x1200	1400x1000 x1200	1400x1000 x1200	1920x1170 x1320	1920x1170 x1320	1920x1170 x1320	1930x1320 x1535	1930x1320 x1535
Compressed air interface size		G1"	G1"	G1"	G1"	G1"	G1½"	G1½"	G2"	G2"	G2"
Total weight	Kg	480	500	520	520	560	1050	1050	1610	1610	1880
Rated power supply	PH/V/HZ	3/415/50	3/415/50	3/415/50	3/415/50	3/415/50	3/415/50	3/415/50	3/415/50	3/415/50	3/415/50
Start-up mode		Y-Δ	Y-Δ	Y-Δ	Y-Δ	Y-Δ	Y-Δ	Y-Δ	Y-Δ	Y-Δ	Y-Δ
Rated exhaust pressure											

The company on product improvement and reserves the right of design improvement parameters are subject to change without prior notice.

Axial loads act on both sides of the main rotor.



Radial loads act on both the top and underside of the main rotor.

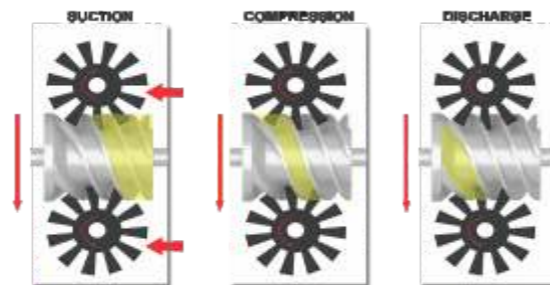

Technical Specification (Permanent Magnet Motor)

		OF-10WRP	OF-15WP	OF-20WP	OF-25WP	OF-30WP	OF-40WP	OF-50WP	OF-60WP	OF-75WP	OF-100WP
Item	Unit	Specification	Specification	Specification	Specification	Specification	Specification	Specification	Specification	Specification	Specification
Rated exhaust pressure	MPa	0.7/0.8/1.0	0.7/0.8/1.0	0.7/0.8/1.0	0.7/0.8/1.0	0.7/0.8/1.0	0.7/0.8/1.0	0.7/0.8/1.0	0.7/0.8/1.0	0.7/0.8/1.0	0.7/0.8/1.0
Rated exhaust capacity	m3/min	1.2/1.1/1.0	1.6/1.5/1.3	2.4/2.3/2.0	3.1/2.8/2.5	3.7/3.4/3.0	5.2/4.7/4.3	6.1/5.6/5.0	7.5/6.8/6.0	10.0/9.0/7.8	13.0/12.0/10.0
Water lubrication	L	20	20	27	27	27	40	40	40	100	100
Intake temperature	C°	2-40C° Under atmospheric pressure	2-40C° Under atmospheric pressure	2-40C° Under atmospheric pressure	2-40C° Under atmospheric pressure	2-40C° Under atmospheric pressure	2-40C° Under atmospheric pressure	2-40C° Under atmospheric pressure	2-40C° Under atmospheric pressure	150 Under atmospheric pressure	200 Under atmospheric pressure
Exhaust temperature	C°	ambient temperature +20C°	ambient temperature +20C°	ambient temperature +20C°	ambient temperature +20C°	ambient temperature +20C°	ambient temperature +20C°	ambient temperature +20C°	ambient temperature +20C°	ambient temperature +20C°	ambient temperature +20C°
Drive mode		Direct driven	Direct driven	Direct driven	Direct driven	Direct driven	Direct driven	Direct driven	Direct driven	Direct driven	Direct driven
RPM	rpm	2940	2940	2940	2940	2940	2940	2940	2960	2960	2960
Rated power	kw	7.5	11	15	18.5	22	30	37	45	55	75
Exhaust oil content	ppm	0	0	0	0	0	0	0	0	0	0
Cooling method		Water cooling	Water cooling	Water cooling	Water cooling	Water cooling	Water cooling	Water cooling	Water cooling	Water cooling	Water cooling
Noise Level	dB(A)	61	61	61	61	61	64	66	66	66	70
Outline size	LxWxH (mm)	1100x800 x1000	1100x800 x1000	1400x1000 x1200	1400x1000 x1200	1400x1000 x1200	1920x1170 x1320	1920x1170 x1320	1920x1170 x1320	1930x1320 x1535	1930x1320 x1535
Compressed air interface size		G1"	G1"	G1"	G1"	G1"	G1½"	G1½"	G2"	G2"	G2"
Total weight	Kg	520	550	600	600	630	1150	1150	1750	1750	2080
Rated power supply	PH/V/HZ	3/415/50	3/415/50	3/415/50	3/415/50	3/415/50	3/415/50	3/415/50	3/415/50	3/415/50	3/415/50
Start-up mode		A/C Drive	A/C Drive	A/C Drive	A/C Drive	A/C Drive	A/C Drive	A/C Drive	A/C Drive	A/C Drive	A/C Drive
Rated exhaust pressure											

The company on product improvement and reserves the right of design improvement parameters are subject to change without prior notice.

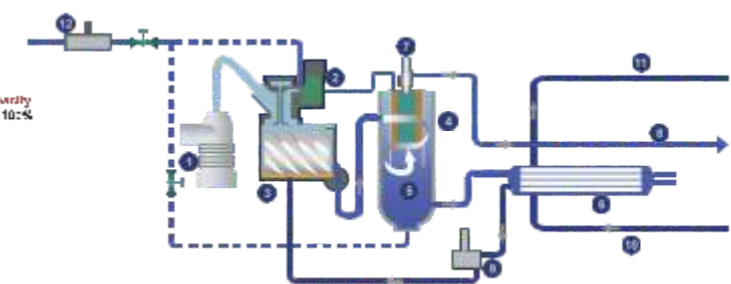
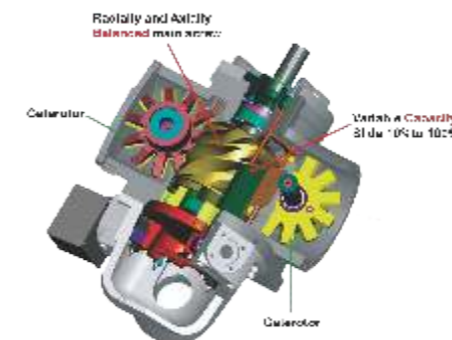

1. Air Filter
2. Inlet Valve
3. Air End
4. Water Separator Tank
5. Water
6. Water Cooler
7. Min. Pressure Valve
8. Air Outlet
9. Water Filter
10. Chilled Water Inlet
11. Water Outlet
12. Make Up Water Line

Dry & Clean Compressed Air

Micro Filter



Technical Specification

Base Model	Nominal Capacity cfm	Maximum Pressure Bar g	Air Connection In / Out	Rated Power* kW Air Cooled
DSR-7.5F	25	16	½"BSP(F)	0.15
DSR-10F	45	16	½"BSP(F)	0.20
DSR-15F	68	16	1"BSP(F)	0.40
DSR-20F	85	16	1"BSP(F)	0.50
DSR-25F	100	16	1½"BSP(F)	0.60
DSR-30F	134	16	1"BSP(F)	1.00
DSR-40F	180	16	1½"BSP(F)	0.90
DSR-50F	250	16	2"BSP(F)	1.40
DSR-60F	300	16	2"BSP(F)	1.60
DSR-75F	400	16	2"BSP(F)	1.90
DSR-100F	500	16	3"NB ASME Flg	2.30
DSR-125F	600	16	3"NB ASME Flg	2.80
DSR-180F	800	16	3"NB ASME Flg	3.80
DSR-220F	1000	16	4"NB ASME Flg	5.00
DSR-250F	1250	16	4"NB ASME Flg	5.70
DSR-300F	1500	12.5	5"NB ASME Flg	6.80
DSR-400F	2000	12.5	6"NB ASME Flg	8.70
DSR-500F	2500	12.5	6"NB ASME Flg	11.00

The company on product improvement and reserves the right of design improvement parameters are subject to change without prior notice.

High Pressure Air Dryer

Model	Capacity cfm	Maximum Working Pressure Kg./sg.cm
VDH - 002	25	35
VDH - 004	45	35
VDH - 006	68	35
VDH - 008	80	35
VDH - 010	100	35
VDH - 012	125	35
VDH - 015	150	35
VDH - 020	200	35
VDH - 025	250	35



Schematic Diagram

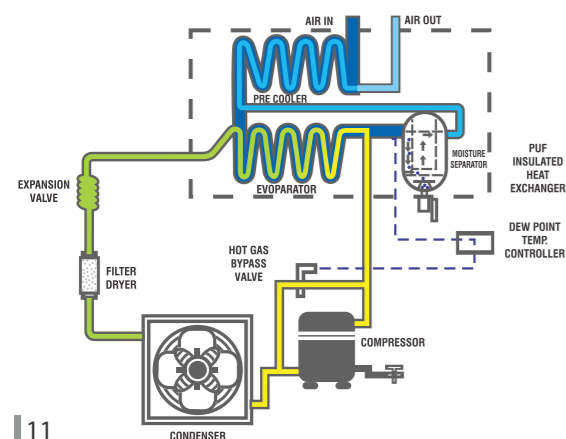

Features

- Environment Friendly
- More Reliability
- Power Saving
- Consistent Dew Point
- Low Pressure Drop
- Compact Design
- Ease of Installation
- Reduced Maintenance



Description

Compressed air contains considerable quantity of solid & oil impurities. These impurities will be the major cause of downtime in compressed air systems. Venus with its rich experience provides innovative solutions to produce clean air by means of using sophisticated filtering system. Venus Compressed Air Filters (Microfilters) are designed to remove solid & oil residue from compressed air system.

Catagories

- Pre Filter PF (Pleated Cellulose Acetate)**
Bulk liquid and partial removal down to 3 micron.
- After Filter AF (Borosilicate glass fiber)**
Liquid and partial removal down to 0.1 micron, residual oil content 0.5 mg/m³.
- Final Filter FF (Borosilicate glass fiber)**
Liquid and partial removal down to 0.01 micron, residual oil content 0.01 mg/m³.

Features

- Venus Compressed air filters have High quality large filtering media
- Venus Compressed Air Filters have Epoxy resin treated housings
- Venus Compressed air filters are designed for Very low pressure drop
- Venus compressed air filters have Differential pressure indicators
- Particle removal: 0.01 to 50 μm
- Oil retention: 0.03 to 5 mg/m³
- Inlet air temperature: 0°C to 80°C Request

Technical Specification

Model	DSR 015 P	DSR 015 S	DSR 024 P	DSR 024 S	DSR 035 P	DSR 035 S	DSR 060 P	DSR 060 S	DSR 090 P	DSR 090 S	DSR 120 P	DSR 120 S
Capacity	CFM	56.51	56.51	84.76	84.76	141.28	141.28	247.24	247.24	406.18	406.18	529.8
Grade	μM	1	0.01	1	0.01	1	0.01	1	0.01	1	0.01	0.01
Oil Remain	PPM	1	0.1	1	0.1	1	0.1	1	0.1	1	0.1	0.1
Max. Pre.	Bar	10	10	10	10	10	10	10	10	10	10	10
Max. Temp.	C	80	80	80	80	80	80	80	80	80	80	80
Connection	Inch	G 1"	G 1"	G 1"	G 1"	G 1.5"	G 1.5"	G 1.5"	G 1.5"	G 2"	G 2"	G 2.5"

The company on product improvement and reserves the right of design improvement parameters are subject to change without prior notice.

Reciprocating Air Compressor

Single Stage Units (belt Drive)

MODEL	OB21 0812-2	OB21 0812-3	OB21 HK-5	OB 21 GN-7.5	OB 21 JN-10	OB 31 JN-15	OB 31 LN-20
No. of Cylinders & Stages	Two / One	Two / One	Two / One	Two / One	Two / One	Three / One	Three / One
Piston Displacement Capacity	266 ltr/min 9.40 cfm	332 ltr/min 11.70 dfm	793 ltr/min 28 cfm	841 ltr/min 30 cfm	1038 ltr/min 36.60 dfm	2190 ltr/min 74.40 cfm	116 ltr/min 81.20 cfm
Maximum Working Pressure	8.50 bar 123 psi	8.50 bar 123 psi	6.00 bar 87 psi	7.00 bar 102 psi	6.00 bar 87 psi	6.00 bar 87 psi	6.00 bar 87 psi
Air Receiver Capacity - liters (Including Accessories)*	150	225	225	225	300	500	300-500
Capacity - hp / kw	2 hp 1.50 kw	3 hp 1.50 kw	5 hp 3.75 kw	7.50 hp 5.60 kw	10 hp 7.50 kw	15 hp 11.20 kw	20 hp 15 kw

*Standard Accessories The Air Receiver is equipped with Pressure gauge, Safety valve, Air delivery valve, manual water drain valve, Automatic on-off pressure control switch, Motor sliding Rail, Motor Pulley, "V" Belt Set, Belt Safety Guard etc.

Double Stage Units (belt Drive)

MODEL	OB22 HK-3	OB22 HK-5	OB22 LN-10	OB22 LN-12.5	OB32 LN-15	OB32 LN-20
No. of Cylinders & Stages	Two / One	Two / One	Two / One	Two / One	Two / One	Three / Two
Piston Displacement Capacity	302 ltr/min 10.70 cfm	440 ltr/min 15.50 cfm	1013 ltr/min 35.90 cfm	1155 ltr/min 40.80 cfm	1877 ltr/min 66.30 cfm	2269 ltr/min 80.10 cfm
Maximum Working Pressure	10 bar 145 psi	10 bar 145 psi	10 bar 145 psi	10 bar 145 psi	10 bar 145 psi	10 bar 145 psi
Air Receiver Capacity - litres (Including Accessories)*	150	225	300	300	500	500
Capacity - hp / kw	3 hp 1.50 kw	5 hp 3.75 kw	10 hp 7.50 kw	12.50 hp 9.30 kw	15 hp 11.20 kw	20 hp 15 kw

*Standard Accessories The Air Receiver is equipped with Pressure gauge, Safety valve, Air delivery valve, manual water drain valve, Automatic on-off pressure control switch, Motor sliding Rail, Motor Pulley, "V" Belt Set, Belt Safety Guard etc..

Single Stage Units (direct Drive)

MODEL	OD 11BC-0.25	OD 21BC-0.5	OD 21BC-1.0	OD 21DC-1.0
No. of Cylinders & Stages	One / One	Two / One	Two / One	Two / One
Piston Displacement Capacity	45 ltr/min 1.60 cfm	90 ltr/min 3.20 cfm	90 ltr/min 3.20 cfm	130 ltr/min 4.60 cfm
Maximum Working Pressure	8.50 bar 123 psi	8.50 bar 123 psi	10 bar 145 psi	8.50 bar 123 psi
Air Receiver Capacity - litres (Including Accessories)*	25~45	25~45	45~70	45~70
Electric Power	1 ph. 215 V	1 ph. 215 V	1 ph. / 215 V 3 ph. / 415 V	1 ph. / 215 V 3 ph. / 415 V
Capacity - hp / kw	0.25 hp 0.19 kw	0.50 hp 0.37 kw	1.00 hp 0.75 kw	1.00 hp 0.75 kw

*Standard Accessories The Air Receiver is equipped with Pressure gauge, Safety valve, Air delivery valve, manual water drain valve, Electric Motor & Automatic on-off pressure control switch.



Model	Motor H.P.	Piston Displacement		Maximum Pressure		Tank Capacity
		C.F.M.	L.P.M.	Kg/cm ² g	Psig	Liters
Two Stage Compressors						
VC-3340	3.00	11.25	318	12.50	175	150
VC-3475	7.50	22.0	622	12.50	175	225
VC-284	2.00/3.00	7.59/10.80	215/305	12.50	175	150
VC-282	5.00/7.50	17.30/20.00	490/570	12.50	175	225
VC-303	7.50/10.00	26.23/31.80	740/897	12.50	175	225/300
VC-4545	7.50/10.00	29.81/37.80	843/1070	12.50	175	225/300
VC-111T2	10.00/12.50	40.00/49.50	1130/1400	12.50	175	300/500
VC-65T	15.00/20.00	63.50/84.80	1800/2310	12.50	175	500
VC-75T2	25.00/30.00	99.00/110.00	2800/3100	12.50	175	500
VC-111T	15.00	55.00	1550	17.50	250	300

Single Stage Compressors

VC-285	3.00	15.80	430	5.62	80	150
VC-294	5.00	26.50	750	5.62	80	225
VC-305	7.50	40.00	1130	5.62	80	250
VC-57S	10.00	68.10	1928	4.21	60	300
VC-57S2	12.50	88.00	2490	2.81	40	300
VC-65S2	15.00	81.60	2305	3.52	50	450
VC-65S2D	20.00	127.80	3610	2.81	40	500

Multistage High Pressure Compressors

VC-261	3.00	7.60	210	35.15	500	150
VC-47T2	7.50/10.00	24.00/32.25	680/915	35.15	500	300
VC-47T2	12.50	36.36	1030	35.15	500	300
VC-57T2	15.00/20.00	41.80/49.50	1180/1400	35.15/56.25	500/800	500
VC-65TH	15.00/20.00	55.00/73.00	1557/1980	30.00	427	500

Single/Two Stage Vacuum Pumps

Model	Motor hp	No. of Cylinders	Piston Displacement cfm	Vacuum (Hg) Pressure inches
285V	1.50	2	21.60	29.00
285VT	1.50	2	10.80	29.60
294V	2.00	2	34.60	29.00
294VT	2.00	2	17.30	29.65
305V	5.00	2	60.00	29.00
305VT	5.00	2	30.00	29.70
57V	7.50	2	110.00	29.00
57VT	7.50	2	55.00	29.65
65V	10.00	3	149.60	29.20
65VT	10.00	3	99.00	29.65

The company on product improvement and reserves the right of design improvement parameters are subject to change without prior notice.

