

**A MEGA INDUSTRIAL EXHIBITION**



FULFILLING EXPECTATION WITHOUT EXCUSE

500+  
STALLS



10,000 +  
PRODUCT  
DISPLAY



B2B & B2C  
MEETINGS



50,000 +  
EXPECTED  
VISITORS

[www. engiexpo.com](http://www.engiexpo.com)

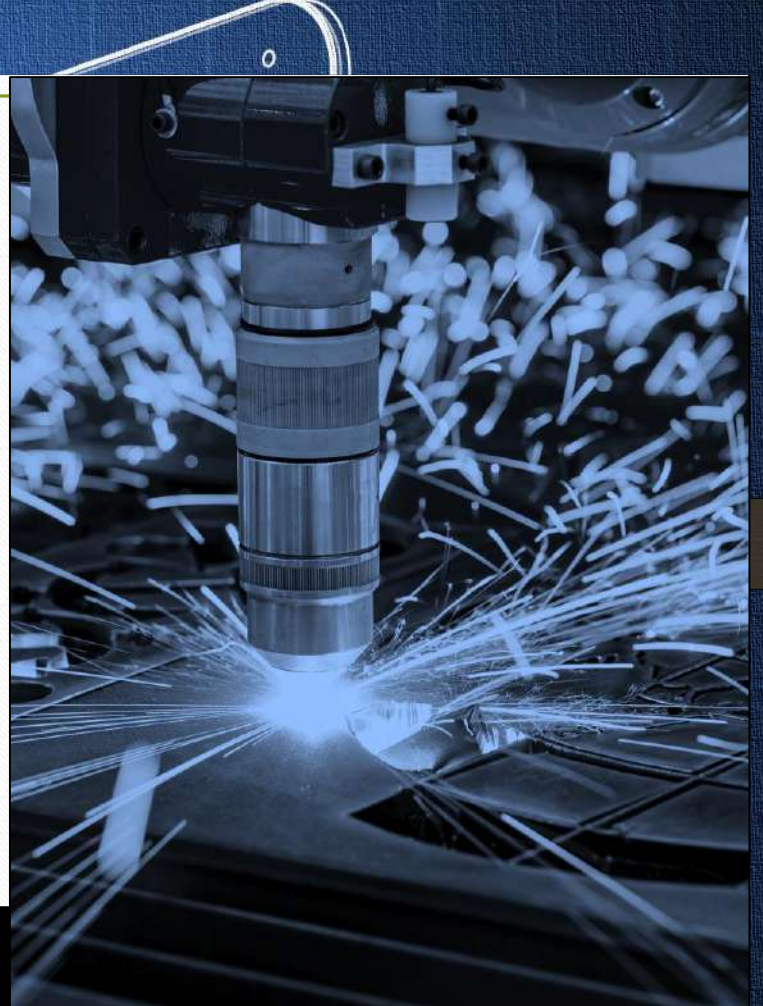

# Upcoming Exhibition

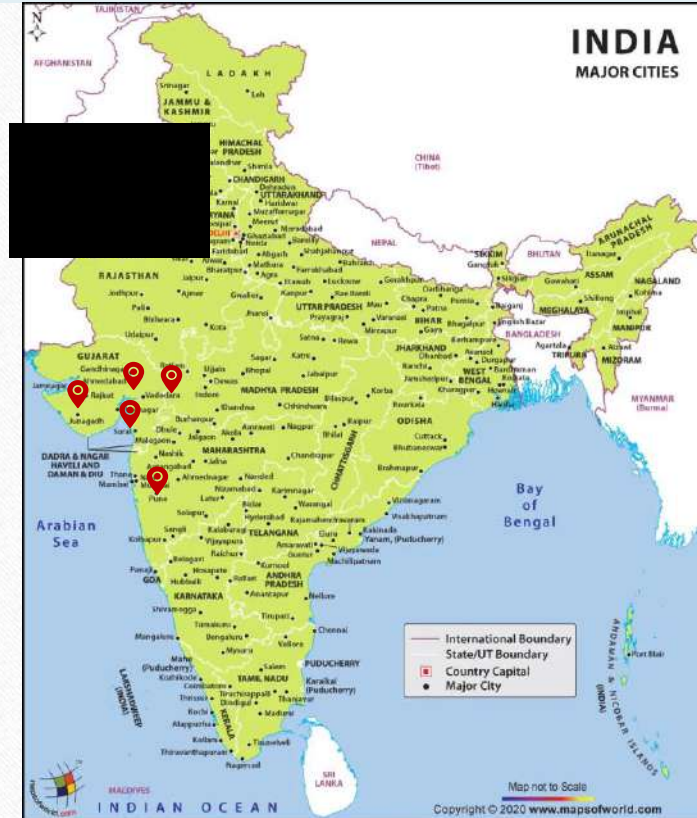

**13th  
EDITION**

**PUNE – AUTO CLUSTER EXHIBITION CENTRE  
28 | 29 | 30 NOVEMBER 2024**

**14th  
EDITION**

**AHMEDABAD – GMDC GROUND  
21 | 22 | 23 DECEMBER 2024**

**15th  
EDITION**

**SURAT – VANITA VISHRAM GROUND  
01 | 02 | 03 FEBRUARY 2025**

**16th  
EDITION**

**JAIPUR – Novotel Jaipur Convention Centre, Jaipur  
Exhibition & Convention Centre  
22 | 23 | 24 NOVEMBER 2025**

**17th  
EDITION**

**RAJKOT – NSIC GROUND  
21 | 22 | 23 | 24 DECEMBER 2025**

**18th  
EDITION**

**VADODARA  
24 | 25 | 26 JANUARY 2026**

## About The EngiExpo & Organizer

**ENGIEXPO Is A Well-Known Name For Industrial Exhibition Organizers In Gujarat. We Have Been Into The Space Selling Concept For The Last 20 Years. With Hard Work and Determination, Along With A Dedicated Team, We Have Gained Huge Success. Our Motto Is To Provide The Right Platform To The Manufacturer Or Trader Where 2Way Communication Is Possible Between Buyer And Seller.**

**We ENGIEXPO is well-known for hosting India's Largest Industrial Exhibition. From 2016 until the present, we have finished the tenth expo. B2B and B2C communication takes place at our expo, which means that both the vendor and the buyer can communicate directly with one other. Our organization, 2 Way Advertising, is a top show organizer. We are exceeding expectations without hesitation.**

**The Event Management & Industrial Exhibitions Organizing Business Is Always Considered As An Investment At ENGIEXPO. We Have A Rich Experience That Obviously Speaks About The Value We Have Delivered To Our Clients In The Form Of Business Generated Through Our Exhibitions.**

**We Want Our Customer To Grow Their Business. Here, we are serving you so that our India can become one of the leading industrial belts. We encourage our staff to make the work happen more precisely. We Are Focusing On Giving Our Clients A Long-Term Profit In A Short-Term Period. We Are Here To Give Your Ideas A Way So That You Will Be Able To Establish A Business That Has Totally New And Creative Concepts.**

# Why Exhibit Engiexpo ?

**ENGIEXPO has established itself as a famous brand in the world of exhibitions and trade shows. ENGIEXPO began gaining international prominence for displaying the complete value chain for engineering industries with a concentrated approach with its 10th consecutive and successful MEGA event, which received significant support and response from the industries.**

- **Connect with clients face-to-face**
- **Build brand awareness**
- **Creating Business Networks**
- **The Competition in the open market**
- **Review of a Product**
- **Showcasing**
- **Launching a Product**
- **Identifying new customer groups**
- **Finding Dealers**
- **Carrying out effective Advertising**
- **Increasing profitability**
- **Expanding distribution**
- **Developing research and sales activities by information share**

# HIGHLIGHTS ENGIEXPO – INDUSTRIAL EXHIBITION

- 1,00,000 Sq. Mtr. Area Covered By EngiExpo
- Official Timings for Quality Visitors 10:00 Am to 06:00 Pm.
- Fully Subjective Exhibition Till Now in India
- 30 Persons Team for Parking Area to Easy Entry and Exit
- 500+ Stall From 9 Sq. Mtr. To 108 Sq.Mtr.
- One-Way Entry for Every Visitors.
- Each and Every Stall Has to Be Visit Concept.
- Exhibitors from Across India and overseas.
- Supported by More Than 5 Different Associations.
- Free Entry Subject to Registration.
- 80% Visitors Are B2B Segments & Rest of 20% Are from B2C+General.
- 99% Visitors Got What They Want.
- Almost 75% Products Are Sold in Just 4-3 Days.
- FOC basis hydra & forklifts for subjective exhibitors for loading / unloading.
- Free and Easy Loading / Unloading & Entry / Exit Process.
- 75% Exhibitors Got New Area and Horizon for Their Existing Business.
- 95% Exhibitors Got New Suppliers as Well as Vendors.
- 20+ Subjective and Dedicated Agencies to Fulfill Each & Every Requirements of Exhibitors as Well as Visitors.
- Also provided digital visiting card with QR code for every exhibitor.



## **FOCUSED CATEGORY**

- ✓ **MACHINE TOOL / AUTOMATION**
- ✓ **POWER TOOL / HAND TOOL**
- ✓ **WELDING / CUTTING / ABRASIVE / SAFETY**
- ✓ **TEXTILE / DIAMOND/ EMBROIDERY**
- ✓ **MATERIAL HANDLING / CONSTRUCTION**
- ✓ **ELECTRICAL / ELECTRONICS PRODUCTS**
- ✓ **WEIGHING SCALE / SCIENTIFIC GLASS**
- ✓ **FASTENERS / PNEUMATIC TOOLS**
- ✓ **RENEWABLE ENERGY / SOLAR**
- ✓ **BUSINESS / I.T. / FINANCE Etc.....**

# NUMBER OF VISITORS TO ENGIEXPO VADODARA IN 2022

- MANUFACTURER / ENGINEER
- TRADERS / DISTRIBUTOR
- DESIGNING / PRODUCTION / TESTING
- CONSULTING
- PURCHASING
- MANAGEMENT / GENERAL AFFAIRS / ACCOUNTING
- SYSTEM MANAGEMENT / MAINTENANCE
- INVESTIGATION/ PLANNING / MARKETING
- PUBLIC INFORMATION / ADVERTISEMENT
- SALES MANAGER
- R & D
- OTHER OCCUPATION / STUDENT / OTHER

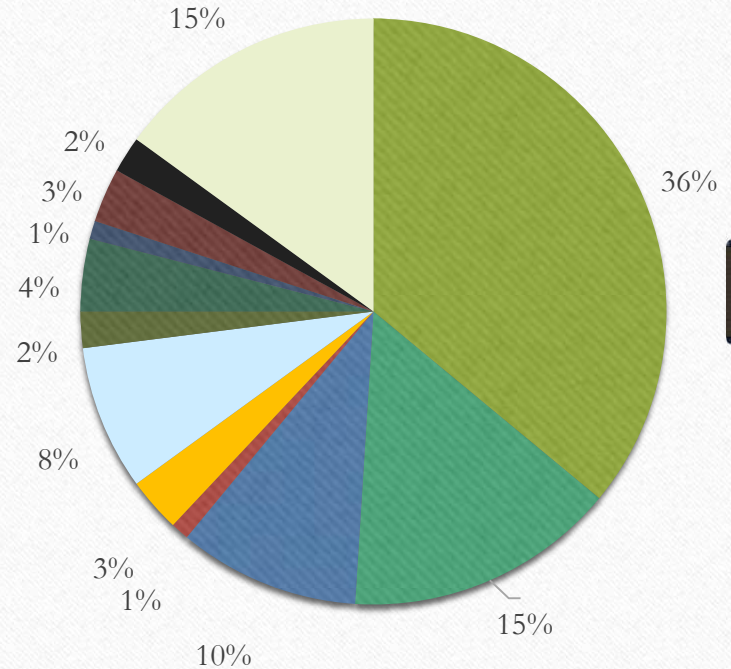

# NUMBER OF VISITORS TO ENGIEXPO AHMEDABAD IN 2022

- MANUFACTURER / ENGINEER
- TRADERS / DISTRIBUTOR
- DESIGNING / PRODUCTION / TESTING
- CONSULTING
- PURCHASING
- MANAGEMENT / GENERAL AFFAIRS / ACCOUNTING
- SYSTEM MANAGEMENT / MAINTENANCE
- INVESTIGATION/ PLANNING / MARKETING
- PUBLIC INFORMATION / ADVERTISEMENT
- SALES MANAGER
- R & D
- OTHER OCCUPATION / STUDENT / OTHER

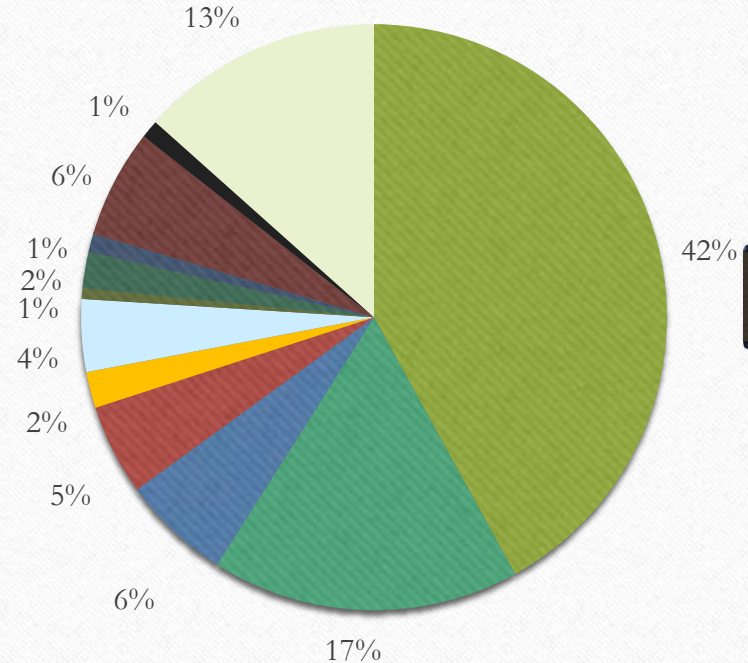



# NUMBER OF VISITORS TO ENGIEXPO SURAT IN 2023

- MANUFACTURER / ENGINEER
- TRADERS / DISTRIBUTOR
- DESIGNING / PRODUCTION / TESTING
- CONSULTING
- PURCHASING
- MANAGEMENT / GENERAL AFFAIRS / ACCOUNTING
- SYSTEM MANAGEMENT / MAINTENANCE
- INVESTIGATION/ PLANNING / MARKETING
- PUBLIC INFORMATION / ADVERTISEMENT
- SALES MANAGER
- R & D
- OTHER OCCUPATION / STUDENT / OTHER

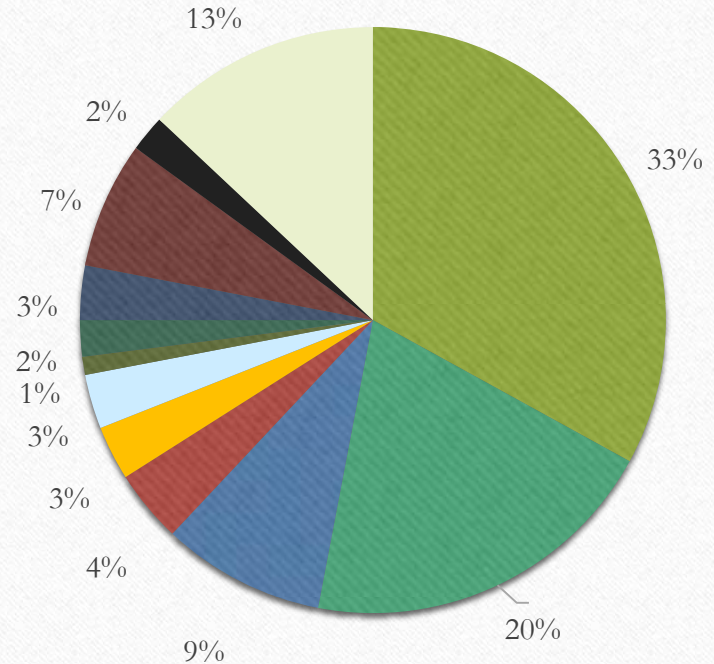

# NUMBER OF VISITORS TO ENGIEXPO RAJKOT IN 2023

- MANUFACTURER / ENGINEER
- TRADERS / DISTRIBUTOR
- DESIGNING / PRODUCTION / TESTING
- CONSULTING
- PURCHASING
- MANAGEMENT / GENERAL AFFAIRS / ACCOUNTING
- SYSTEM MANAGEMENT / MAINTENANCE
- INVESTIGATION/ PLANNING / MARKETING
- PUBLIC INFORMATION / ADVERTISEMENT
- SALES MANAGER
- R & D
- OTHER OCCUPATION / STUDENT / OTHER

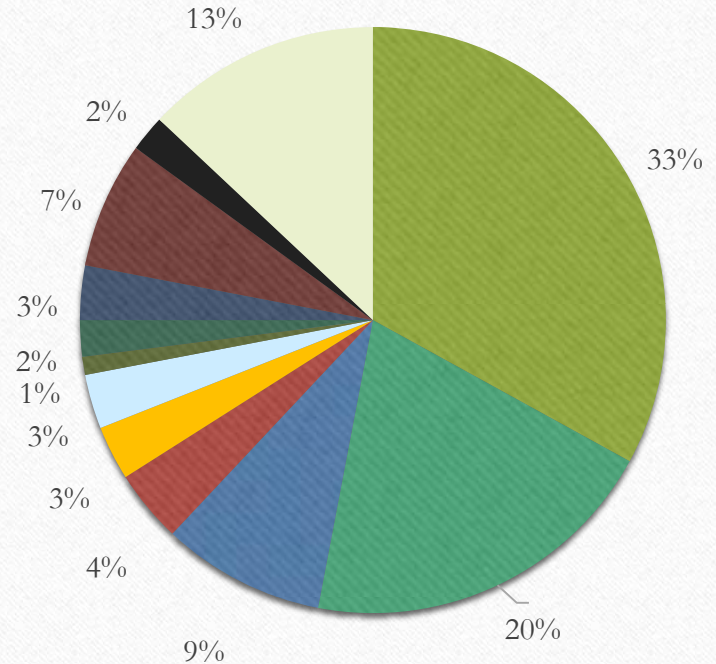

# NUMBERS AND ANALYSIS OF VISITORS

EngiExpo is expected to be a key event for all levels of industrial organizations, the industry of services, traders, and their leaders, such as Directors and entrepreneurs, top executives, business organizers, production managers and executives, retail store engineers, and government trade assign from all over all over the globe.

## 1. NUMBER OF VISITORS TO ENGIEXPO VADODARA IN 2024

- MANUFACTURER / ENGINEER
- TRADERS / DISTRIBUTOR
- DESIGNING / PRODUCTION / TESTING
- CONSULTING
- PURCHASING
- MANAGEMENT / GENERAL AFFAIRS / ACCOUNTING
- SYSTEM MANAGEMENT / MAINTENANCE
- INVESTIGATION/ PLANNING / MARKETING
- PUBLIC INFORMATION / ADVERTISEMENT
- SALES MANAGER
- R & D
- OTHER OCCUPATION / STUDENT / OTHER

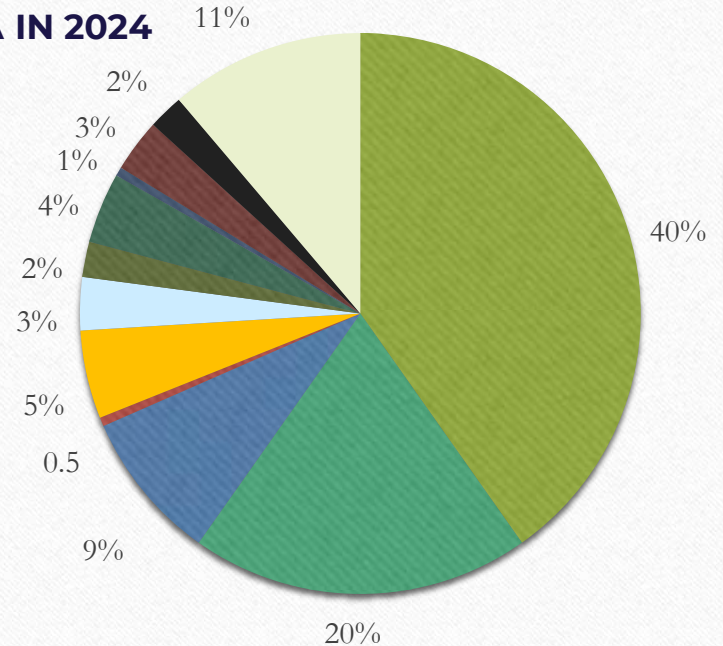

# OUR PROMOTIONAL ACTIVITIES & BRANDING

- ◆ To increase visitor attendance at our exhibition, we use a marketing approach that focuses on getting the right buyers to our exhibitions and increasing footfall during the event. These strategies include:

DIGITAL PROMOTION

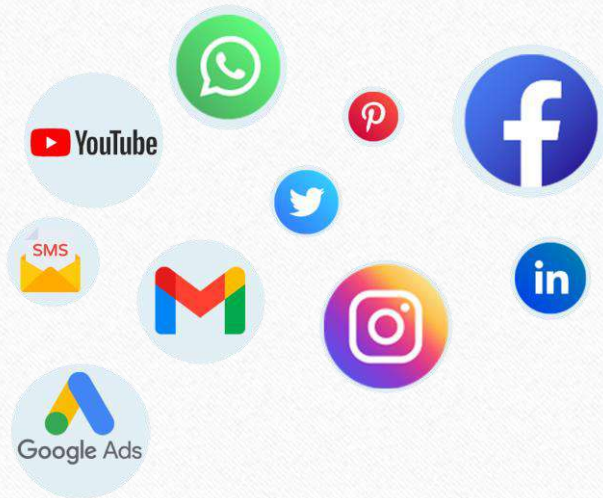

TRADITIONAL PROMOTION



## TITLE SPONSORSHIP PROPOSAL

- ◆ Logo with EngiExpo, Logo on Front Page of Brochure.
- ◆ Logo on Back Page of Brochure.
- ◆ Logo in Newspaper Ad.
- ◆ Name as Title Sponsor in Radio Ad.
- ◆ 108 Sq. Mtr. Stall in Ahmedabad Exhibition.
- ◆ Logo as Title Sponsor in Hoarding.
- ◆ Logo as Title Sponsor in T.V. Ad.
- ◆ Logo as Title Sponsor on Main Gate of Ahmedabad Exhibition.  
(Affective Gate Cost Approx. 6 To 8 Lac.)
- ◆ Internal Branding at Exhibition Promotion as Title Sponsor.

**Amount: - 31 lac + GST**

# PRICE LIST FOR STALL BOOKING

Following a personal discussion, here is the final non-negotiable proposition for you.

EARLY BIRD DISCOUNT						
	SQ. MTR.	Card Rate	Single City	Double City	Triple City	Four / Five City
Per Sq. Mtr.	1	14000/-	9000/-	8500/-	8000/-	7500/-
Book Advt.	Colour Half Page	40000/-	35000/-	60000/-	75000/-	80000/-
Book Advt.	Colour Half Page	60000/-	55000/-	100000/-	135000/-	140000/-
Stall - A	9	126000/-	81000/-	153000/-	216000/-	270000/-
Stall - B	12	168000/-	108000/-	204000/-	288000/-	360000/-
Stall - C	18	252000/-	162000/-	306000/-	432000/-	540000/-
Stall - D	27	378000/-	243000/-	459000/-	648000/-	810000/-
Stall-E (S,R,V)	36	504000/-	324000/-	612000/-	864000/-	1080000/-
Stall-E (Ahd.)	54	756000/-	486000/-	918000/-	1296000/-	1620000/-
Stall-F (S,R,V)	72	1008000/-	648000/-	1224000/-	1728000/-	2160000/-
Stall-F (Ahd.)	108	1512000/-	972000/-	1836000/-	2592000/-	3240000/-

# PRICE LIST

-	Gold Sponsor	Silver Sponsor	Partner Tag
<b>Total Position</b>	<b>3</b>	<b>5</b>	<b>15</b>
<b>Prominent Location (Stall)</b>	<b>54 Sq. Mtr.</b>	<b>36 Sq. Mtr.</b>	<b>27 Sq. Mtr.</b>
<b>Digital Recognition On engiexpo.com &amp; E-Brochure</b>	<b>Company Logo With Hyperlink</b>	<b>Company Logo With Hyperlink</b>	<b>Company Logo Without Hyperlink in Scrolling Position</b>
<b>Branding On Brochure</b>	<b>Logo Printed on Back Page as a Gold Sponsor</b>	<b>Logo Printed on Back Page as a Silver Sponsor</b>	<b>Logo Printed on Back Page as a Subjective Partner</b>
<b>Backdrop @ Conference Hall</b>	<b>Logo Print on Stage Background Flex</b>	<b>Logo Print on Stage Background Flex</b>	<b>Logo Print on Stage Background Flex</b>
<b>Branding on Invitation Card</b>	<b>Logo Printed as a Gold Sponsor (1 Lac)</b>	<b>Logo Printed as a Silver Sponsor (1 Lac)</b>	<b>-</b>
<b>Directory Advt.</b>	<b>Full Page</b>	<b>Full Page</b>	<b>Half Page</b>
<b>Price for 1 Event</b>	<b>15 Lakhs + GST</b>	<b>10 Lakhs + GST</b>	<b>7.5 Lakhs + GST</b>

## MAIN GATE BRANDING ( 10 X 10 FEET )

POSITION	PRICE RS.		POSITION	PRICE RS.
Entry Left 1	100000/-		Exit Right 1	80000/-
Entry Left 2	75000/-		Exit Right 2	60000/-
Entry Left 3	50000/-		Exit Right 3	40000/-
Entry Left 4	25000/-		Exit Right 4	20000/-

- 18% GST Will be Extra • Any Association Member Or Startup Will Get Rs. 500/- Per Sq. Mtr. Extra Discount.
- Startup Date Should Be Less Than 1 Year, Legal Proof is Necessary. • Association Should be Belongs To Our Specified Category.



## **2 Way Advertising will provide you following facilities for 3m X 3m Stall**

- ◆ **1 Nos. Tables**
- ◆ **2 Nos. Moulded Chairs**
- ◆ **1 Nos. 5 Amp. Plug Point**
- ◆ **Carpet Flooring**
- ◆ **Laminated Stall**
- ◆ **3 Participant Badges**
- ◆ **3 Spot Lights**
- ◆ **Name on Fascia (Vinyl)**
- ◆ **100 Nos. Invitation Cards**
- ◆ **1 Quarter page Ad. Free in Participants Directory worth Rs.20000/-**
- ◆ **1 Dustbin**
- ◆ **1 Nos. 20 Liter. Drinking water Jug per day**
- ◆ **1 Nos. QR Code of Digital Visiting Card.**

**Note: No Chairs and Tables will be Provided for Bare Space**

# PUNE - 2024

**Date :**

28 | 29 | 30 November 2024

**Venue :**

Autocluster Exhibition Centre,  
Chinchwad, Pune.

**STALL SIZE :-**

**A - 3M X 3M (9SQ.MTR)**

**B - 4M X 3M (12SQ.MTR)**

**C - 6M X 3M (18SQ.MTR)**

**D - 9M X 3M (27SQ.MTR)**

**E - 6M X 6M (36SQ.MTR)**

**F - 12M X 3M (36SQ.MTR)**

## MACHINE TOOL AUTOMATION

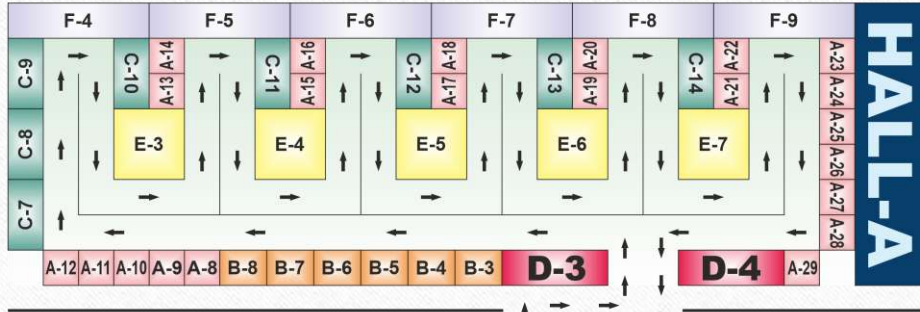

## MATERIAL HANDLING FASTENERS / RUBBER PARTS

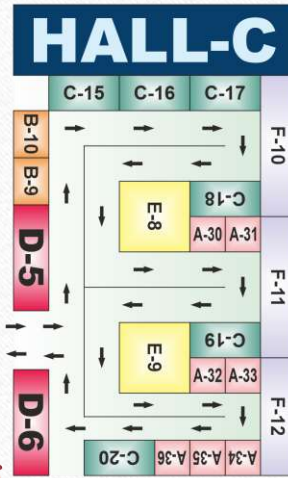

## WELDING / CUTTING / ABRASIVE SAFETY / POWER TOOL / HAND TOOL

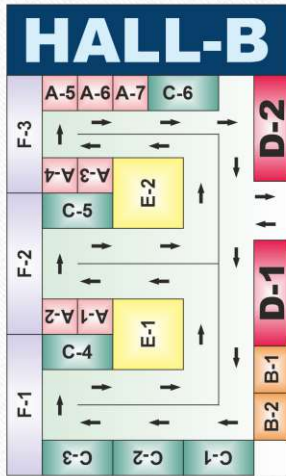

ENTER

EXIT

TOILET



# AHMEDABAD - 2024

**Date :**  
21 | 22 | 23 December 2024

**Venue :**  
GMDC Ground, 132 Feet Ring Road, Ahmedabad - 380052

**STALL SIZE :-**

- A - 3M X 3M (9SQ.MTR)
- B - 4M X 3M (12SQ.MTR)
- C - 6M X 3M (18SQ.MTR)
- D - 9M X 3M (27SQ.MTR)
- E - 9M X 6M (54SQ.MTR)
- F - 12M X 9M (108SQ.MTR)

**PAVILION – OPEN SPACE**

TOILET

GENERAL CAFETERIA

PARTICIPANT CAFETERIA

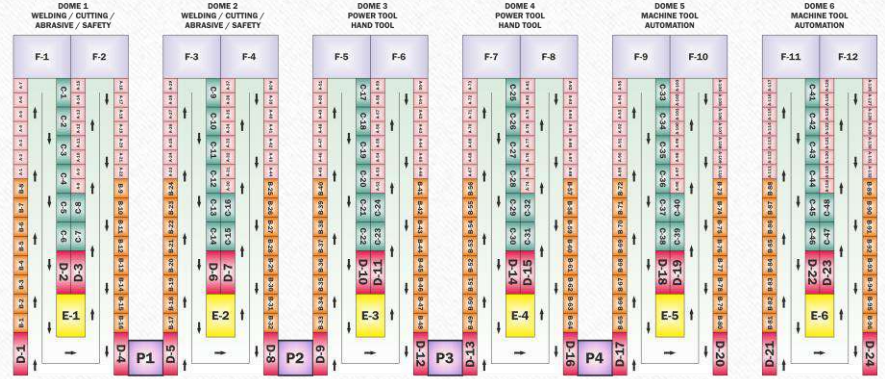

REGISTRATION

MAIN GATE

OFFICE

# SURAT - 2025

**Date :**

01 | 02 | 03 February 2025

**Venue :**

Vanita Vishram Ground,  
Athwa Gate, Surat - 395001

**STALL SIZE :-**

- A - 3M X 3M (9SQ.MTR)
- B - 4M X 3M (12SQ.MTR)
- C - 6M X 3M (18SQ.MTR)
- D - 9M X 3M (27SQ.MTR)
- E - 6M X 6M (36SQ.MTR)
- F - 12M X 6M (72SQ.MTR)

TOILET

GENERAL  
CAFETERIA

PARTICIPANT  
CAFETERIA

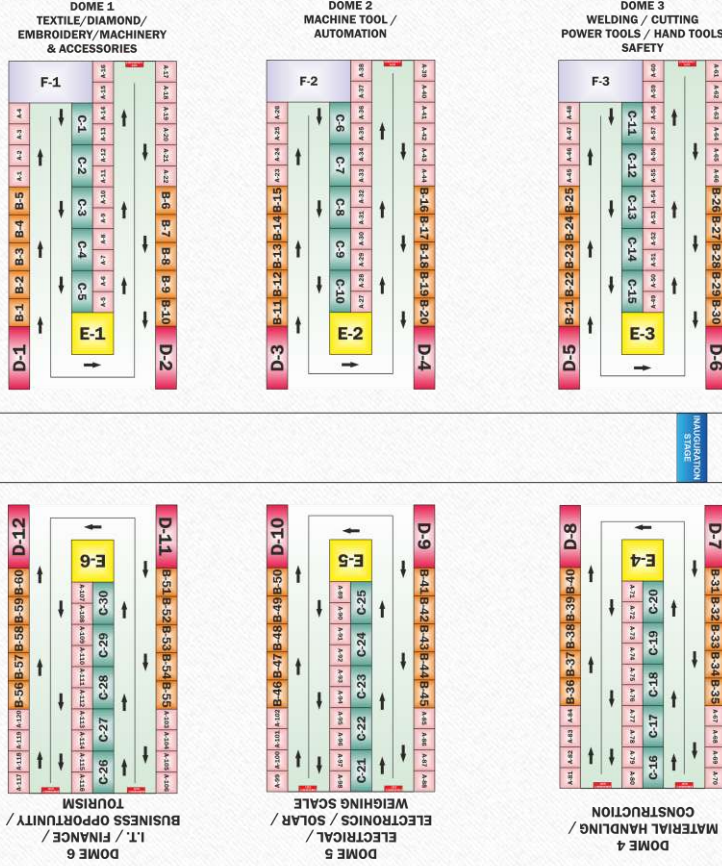

**Date :** 22 | 23 | 24  
NOVEMBER 2025

**Venue :** Novotel Jaipur Convention Centre, Jaipur Exhibition & Convention Centre, Exhibition Ground, EPIP, RIICO Industrial Area, Sitapur, Jaipur-302022.

# JAIPUR - 2025

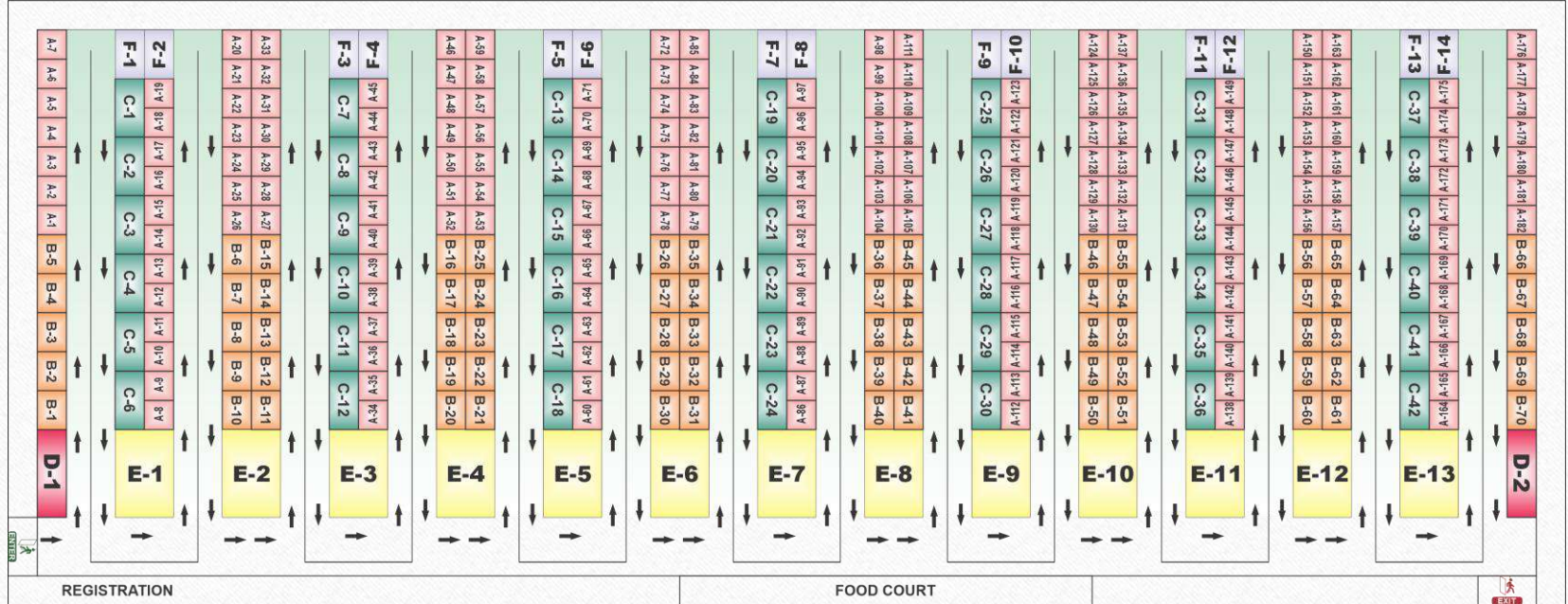

**STALL SIZE :-**

**A - 3M X 3M (9SQ.MTR)**

**B - 4M X 3M (12SQ.MTR)**

**C - 6M X 3M (18SQ.MTR)**

**D - 9M X 3M (27SQ.MTR)**

**E - 9M X 6M (54SQ.MTR)**

**F - 5M X 3M (15SQ.MTR)**

# RAJKOT - 2025

**Date :**

21 | 22 | 23 | 24 DECEMBER 2025

**Venue :**

NSIC GROUND, AJI GIDC,  
RAJKOT

**STALL SIZE :-**

**A - 3M X 3M (9SQ.MTR)**

**B - 4M X 3M (12SQ.MTR)**

**C - 6M X 3M (18SQ.MTR)**

**D - 9M X 3M (27SQ.MTR)**

**E - 6M X 6M (36SQ.MTR)**

**F - 12M X 6M (72SQ.MTR)**

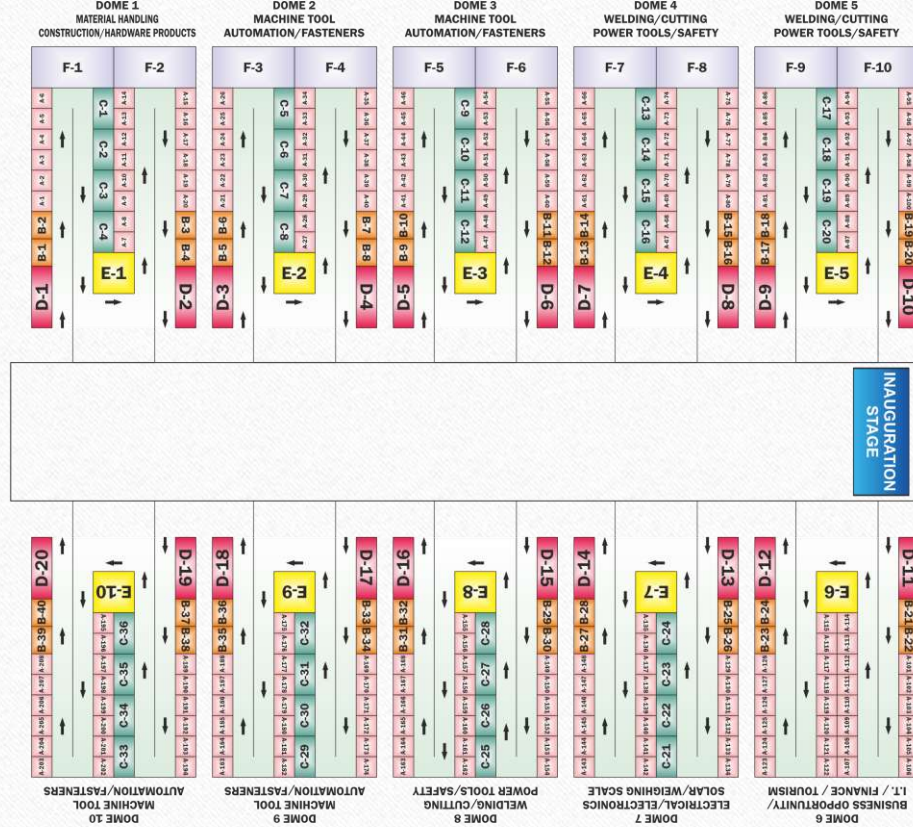

TOILET

GENERAL  
CAFETERIA

PARTICIPANT  
CAFETERIA

REGISTRATION

MAIN GATE

OFFICE

INAUGURATION  
STAGE

# VADODARA - 2026

Date :

24 | 25 | 26 January 2026

**STALL SIZE :-**

- A - 3M X 3M (9SQ.MTR)
- B - 4M X 3M (12SQ.MTR)
- C - 6M X 3M (18SQ.MTR)
- D - 9M X 3M (27SQ.MTR)
- E - 6M X 6M (36SQ.MTR)
- F - 12M X 6M (72SQ.MTR)

TOILET

GENERAL CAFETERIA

PARTICIPANT CAFETERIA



REGISTRATION

MAIN GATE

OFFICE

INAUGURATION STAGE

DOME 1  
MATERIAL HANDLING  
CONSTRUCTION/HARDWARE PRODUCTS

DOME 2  
MACHINE TOOL  
AUTOMATION/FASTENERS

DOME 3  
MACHINE TOOL  
AUTOMATION/FASTENERS

DOME 4  
WELDING/CUTTING  
POWER TOOLS/SAFETY

DOME 5  
WELDING/CUTTING  
POWER TOOLS/SAFETY

DOME 10  
MACHINE TOOL  
AUTOMATION/FASTENERS

DOME 9  
MACHINE TOOL  
AUTOMATION/FASTENERS

DOME 8  
WELDING/CUTTING  
POWER TOOLS/SAFETY

DOME 7  
ELECTRICAL/ELECTRONICS  
SOLAR/WEIGHING SCALE

DOME 6  
BUSINESS OPPORTUNITY/  
I.T. / FINANCE / TOURISM



A MEGA INDUSTRIAL EXHIBITION

 **engí<sup>®</sup>  
expo**









# Thanks!

**JOINTLY ORGANISED BY :**



**More Information :-**

Mo. : +91-98791 11548 / 98796 15979

Email : [engiexpo@gmail.com](mailto:engiexpo@gmail.com) | Web : [www.engiexpo.com](http://www.engiexpo.com)